



# Series 3000 Cooling Tower

## TABLE OF CONTENTS

3	SERIES 3000 COOLING TOWER	11	CUSTOM FEATURES & OPTIONS
5	XE-SERIES 3000 COOLING TOWER	24	ENGINEERING DATA
7	BENEFITS	35	STRUCTURAL SUPPORT
9	CONSTRUCTION DETAILS	37	ALTERNATIVE STRUCTURAL SUPPORT

The NEW Series 3000 Cooling Tower once again redefines the cooling tower industry with expanded selection flexibility and capacity increases of up to 16%. The NEW Series 3000 Cooling Tower provides an extremely efficient solution for all your application needs. Transcending an already superior product the NEW XE-Series 3000 is tailored for projects that require extreme efficiency from the cooling tower. The XE-Series units are at least two times more efficient than conventional cooling towers, far exceeding the requirements of Section J of the Building Code of Australia.



# BAC's Series 3000: The Industry Standard

Large Range of CTI Certified Capacities  
752 to 5944 kW in a Single Cell  
Up to 280 l/s for Process Applications

Industry  
Leading  
Energy  
Efficiency

Most Reliable  
Year-Round  
Operation

Easiest to  
Maintain

Variety of  
Materials of  
Construction

Flexible  
Configurations



# The NEW Series 3000 Cooling Towers

The NEW Series 3000 Cooling Tower continues its industry leading tradition. With expanded selection flexibility and a capacity increase of up to 16%, the Series 3000 Cooling Tower provides an extremely efficient solution for all your application needs.

## Reduced Energy Consumption

- ▶ Most efficient cooling tower in the industry
- ▶ Up to a 16% increase in capacity
- ▶ Exceeds requirements of Section J of the Building Code of Australia

1400 kW Example:	Series 3000	Competition	Competition
Fan kW	15	22	30
Footprint (L x W x H)	2.6 x 5.5 x 3.7m	2.6 x 5.5 x 3.7m	2.6 x 5.5 x 3.7m
Nominal kW	1400	1360	1490

## 1400kW Example: Annual Operating Cost for a 15, 22, 30 kW

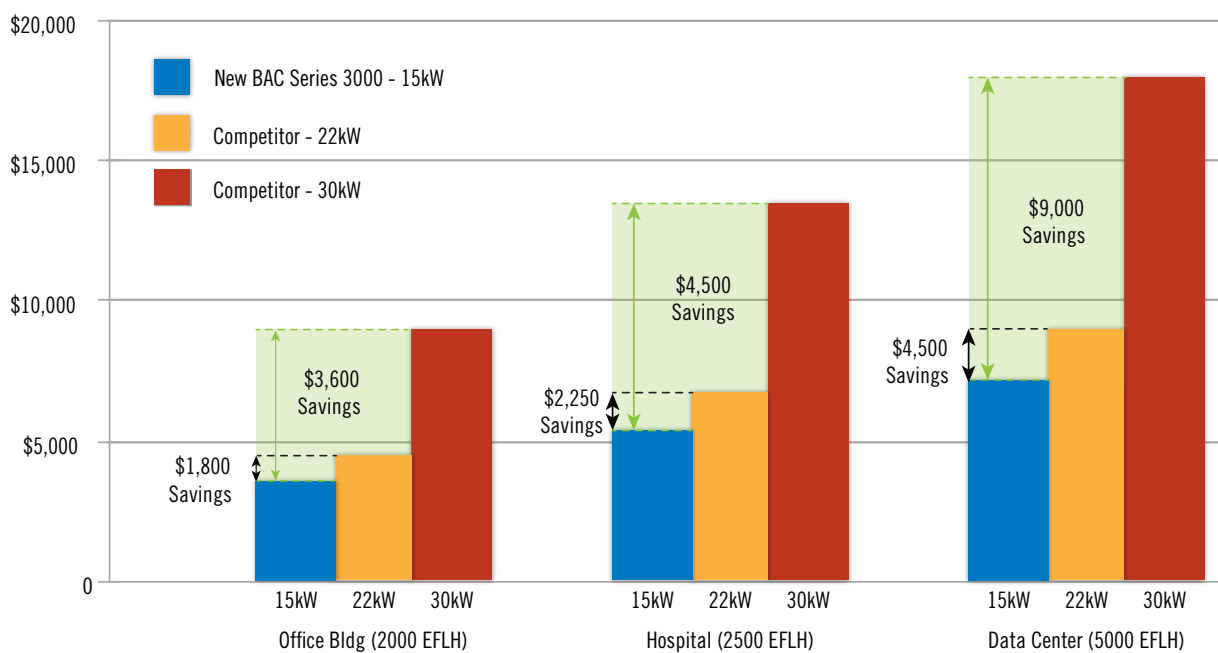

Energy Cost Savings Based on a 1400kW System (\$0.12 kWh)



## Reliable Year-Round Operation

- ▶ Superior winter operating performance
- ▶ BALTDRIVE® POWER TRAIN Fan System
- ▶ Rigid frame construction
- ▶ Meets wind and seismic requirements of the International Building Code (IBC)

## More Selection Flexibility

- ▶ 31 new models
- ▶ 3 new box sizes
- ▶ 69 XE-Series 3000 Cooling Tower models are available in a full array of box sizes

## Enhanced Payback Analysis

- ▶ Provides alternative selections based on energy savings and minimum payback
- ▶ User-defined life-cycle cost inputs
- ▶ XE-Series models featured in selection program

## Easiest to Maintain

- ▶ Direct access to:
  - Cold water basin
  - Hot water basin
  - Drive system
- ▶ Patented hygienic cold water basin
- ▶ Factory assembled access options available for ease of maintenance



New Series 3000 Cooling Tower

Product	Qty	Model	Total Fan Motor (hp)	Tower Pumping Head (ft)	Reserve Capacity (%)	Budget Price (U.S. \$)	Price Mark	Payback (Years)	
LFC	S3000	1	S3E-1020-07P	40.00	4.91	6.00	37,034	1.00	0.02
R1	S3000	1	S3E-1222-06G	30.00	4.33	0.00	37,100	1.00	0.02
R2	S3000	1	S3E-1222-07N	35.00	4.91	4.60	39,760	1.07	0.57
1	S3000	1	S3E-1020-07P	40.00	4.91	6.00	37,034	1.00	0.57
2	S3000	1	S3E-1222-06G	30.00	4.33	0.00	37,100	1.00	0.56
3	S3000	1	S3E-1222-07N	35.00	4.91	4.60	39,760	1.07	0.57
4	S3000	1	XE3E-1424-07L	18.00	4.91	-0.60	41,853	1.12	0.74
5	S3000	1	XE3E-1424-07M	20.00	4.91	9.00	41,800	1.13	0.74
6	S3000	2	XE3E-0510-05K	20.00	3.75	2.40	48,394	1.31	1.77
7	S3000	1	XE3E-1222-10K	10.00	6.71	-1.80	51,589	1.39	1.51
8	S3000	1	XE3E-1222-10L	15.00	6.71	11.80	51,892	1.40	1.85
9	S3000	2	XE3E-0510-04J	15.00	4.33	4.80	55,660	1.50	2.32
10	S3000	1	XE3E-1222-12K	10.00	7.66	5.60	67,263	1.55	2.10
									2.30
									2.35

**Model Details**  
 Motor Info: (1) 30.00 HP Fan Motor per Unit  
 Energy Rating: 60.33 per ASHRAE 90.1, ASHRAE 189 and CA Title 24.

Enhanced Product Selection Software

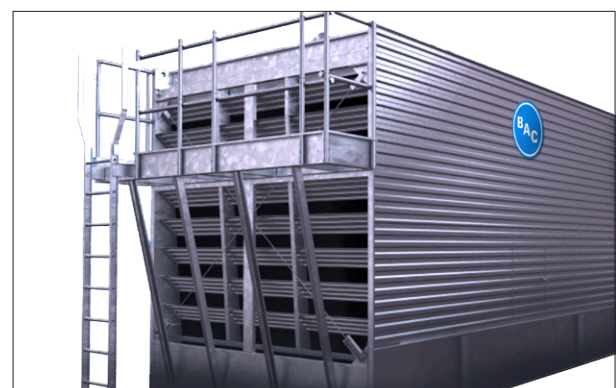

Factory Pre-Assembled Platforms

# XE - Series 3000

The XE-Series 3000 Cooling Tower is the newest addition to BAC's cooling tower portfolio. It is tailored for projects that require an extremely efficient unit to minimize energy costs, reduce sound levels, and contribute to Greenstar Certification Points. XE-Series 3000 Cooling Towers are at least two times more efficient than conventional cooling towers far exceeding the requirements of Section J of the Building Code of Australia.

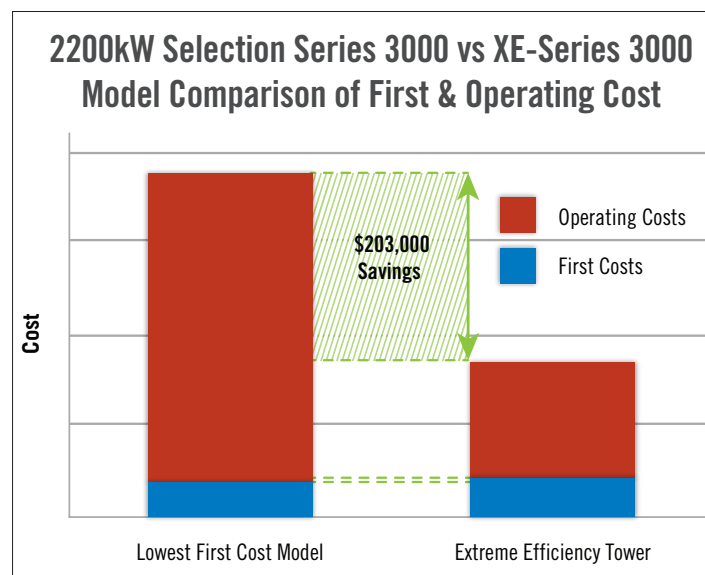

**Note:** Operating costs based on fan kW x \$0.12/kWh x 2500EFLH (equivalent full load hours) x 20 years (2011 ASHRAE Handbook HVAC Applications) x 3% per year energy inflation factor.

## Reduced Sound Levels

- ▶ Sound reduction up to 50% (3dB)
- ▶ Fans optimized to minimize sound levels and maximize efficiency
- ▶ Additional sound reducing options available

## Lowest Operating Costs

- ▶ 37.5% reduction in operating costs for a 2200kW system
- ▶ Payback of less than 2 years



## Increased Operating Reliability

- ▶ BALTIDRIVE® POWER TRAIN Fan System
- ▶ Extends the life of the mechanical drive components (minimum L<sub>10</sub> bearing life 288,000 hours)
- ▶ 5-year motor and drive warranty



The XE-Series 3000 Cooling Tower



## Greenstar Certification Contributions

- ▶ Industry leading energy efficiencies
- ▶ Provides energy cost savings
- ▶ Contributions to energy and emissions points

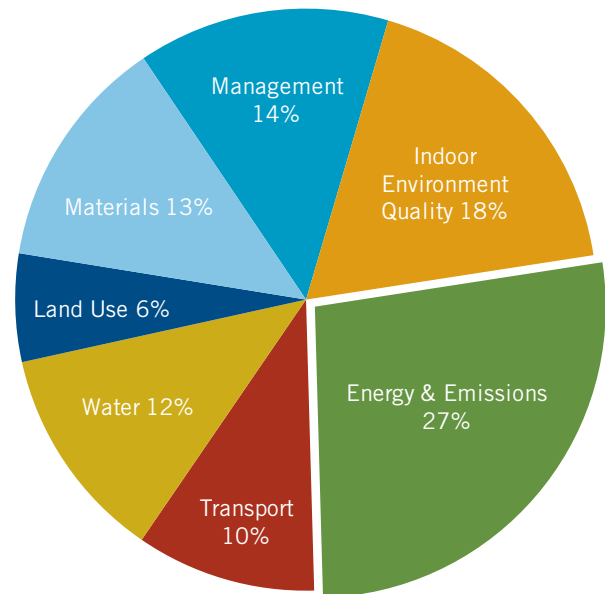

Green Star Weighted Average

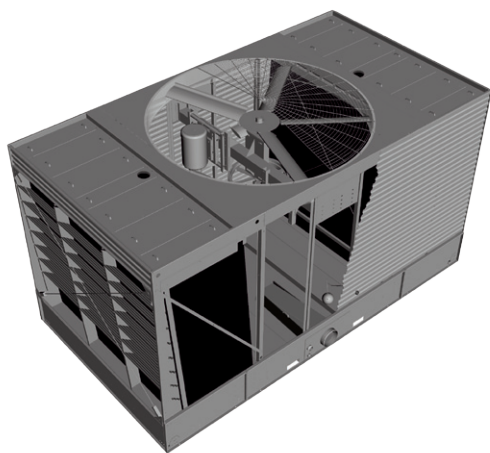

**Lowest Operating Costs**



**Reduced Sounds Levels**



**Increased Operating Reliability**



**Contributes to Greenstar Certification**

**COMPARE > SELECT > SPECIFY >**

# Series 3000 Benefits

## > Low Environmental Impact

### ▶ ENERGY EFFICIENT

- Exceeds the requirements of section J of the BCA for standard design conditions
- MEPS 2 compliant for motors
- Gravity distribution system with low pump head requirements

### ▶ SOUND REDUCTION OPTIONS

- Standard fan is high efficiency and low sound
- For further reduced sound levels, Low Sound Fans, Whisper Quiet Fans, and sound attenuation are available options

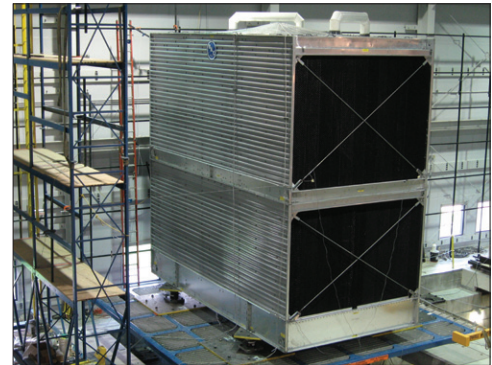

Shake Table Tested Series 3000

## > Durable Construction

- ▶ Meets wind and seismic requirements of the International Building Code (IBC)
- ▶ Designed to withstand wind loads up to 2.85kPa, upgraded units designed to withstand 3.9kPa
- ▶ Seismically verified through dynamic shake table testing up to a  $S_{DS}$  of 3.10g
- ▶ Casing panels constructed of corrosion resistant FRP with rigid frame construction
- ▶ Enhanced longevity with a variety of durable materials of construction



Durable Frame Construction

## > Reliable Year-Round Operation

### ▶ BALTIDRIVE® POWER TRAIN FAN SYSTEM

- Backed by BAC's comprehensive 5-year motor and drive warranty
- Corrosion resistant cast aluminum sheaves with specially designed powerband belts
- Cooling tower duty motors designed for hostile environments

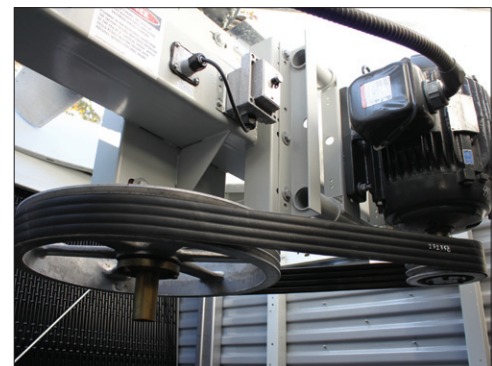

BALTIDRIVE® Power Train Fan System





## > Easy Maintenance

- ▶ Crossflow configuration provides direct access for easy maintenance
- ▶ BALTIDRIVE® Power Train uses state-of-the-art technology to ease maintenance
- ▶ Patented hygienic cold water basin is sloped at the air intakes to eliminate stagnant water and reduce biological growth
- ▶ Fill surface is elevated above the sloped cold water basin floor to facilitate flushing of dirt and debris
- ▶ Hinged access doors provide easy access to the cold water basin and fan drive system
- ▶ Combined inlet shields block sunlight, reducing the potential for algae growth in the cold water basin (option)
- ▶ Factory assembled louver face platforms, internal service platforms, and internal walkways simplify maintenance (option)

## > Easy Installation

- ▶ Rigging guides ensure proper alignment and reduce rigging time
- ▶ Flexible inlet/outlet piping connection locations ensure proper fit for any application
- ▶ Adaptable steel support configuration options, utilizing pre-existing support steel
- ▶ Knockdown units available for field assembly
- ▶ EASY CONNECT® Piping Arrangement reduces installation costs by eliminating overhead piping and piping support requirements (option)
- ▶ Basinless construction ability, ideal for installations using a common sump for multiple tower cells (option)
- ▶ Single point wiring of the fan motor and vibration cut out switch simplifies field installation when ordered with BAC Controls (option)



Internal Walkway and Large Access Door for Easy Maintenance



Factory Assembled Louver Face Platforms



Flexible Piping Arrangement

# Series 3000 Construction Details

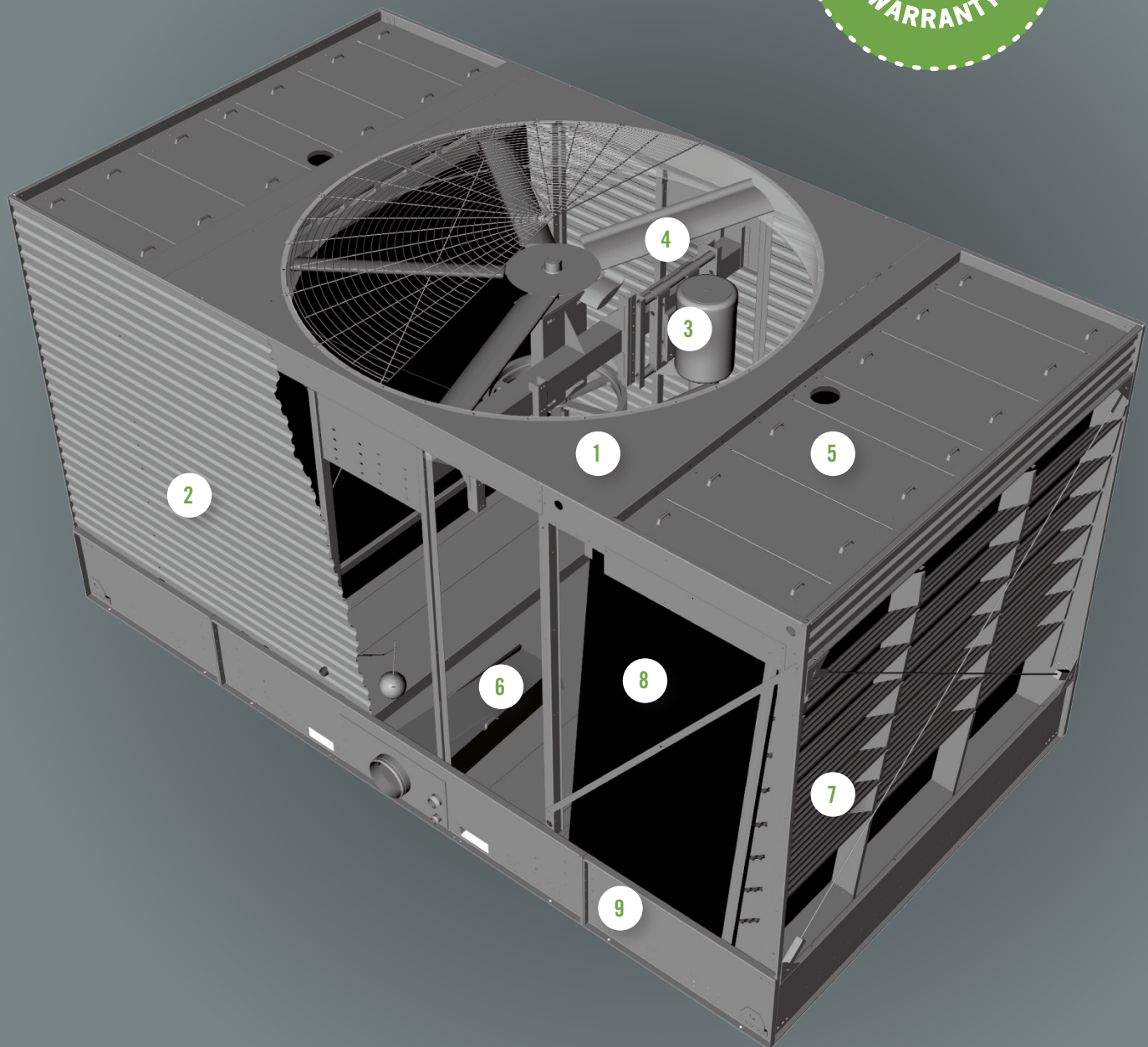

## 1 Heavy-Duty Construction

- ▶ Heavy-gauge G-235 (Z700 Metric) hot-dip galvanized steel frame
- ▶ Meets wind and seismic requirements of the International Building Code (IBC)
- ▶ Shake table tested and verified with seismic ratings up to a  $S_{DS}$  of 3.10g
- ▶ Designed to withstand wind loads of up to 3.9kPa

## 2 FRP Casing Panels

- ▶ Corrosion resistant
- ▶ Maintenance free
- ▶ UV-resistant finish

## 3 BALTIDRIVE® Power Train

- ▶ Premium quality, solid backed, multi-groove belt
- ▶ Corrosion resistant cast aluminum sheaves
- ▶ Heavy-duty bearings with a minimum  $L_{10}$  of 80,000 hours
- ▶ MEPS 2 compliant, cooling tower duty motors fit for VFD applications
- ▶ 5-year motor and drive warranty

## 4 Low Horsepower Axial Fan

- ▶ Quiet operation
- ▶ High efficiency
- ▶ Corrosion resistant

## 5 Water Distribution System

- ▶ Steel covers in easy to remove sections
- ▶ Low pump head gravity distribution basins
- ▶ Large orifice, non-clog nozzles
- ▶ Weir dams provided to create even distribution that will accommodate a flow range of 50% to 100% of the design flow.

## 6 Suction Strainer

- ▶ Designed to offer optimum system protection while still offering a full 50% free area to allow efficient system pump operation
- ▶ Anti-vortexing design built into all BAC strainers
- ▶ Strainer can removed with the flip of a single latch for easy cleaning and maintenance

## 7 Air Intake Louvers

- ▶ Corrosion resistant
- ▶ Maintenance free
- ▶ UV-resistant finish

## 8 BACross® Fill with Integral Drift Eliminators

- ▶ High efficiency heat transfer surface
- ▶ Polyvinyl chloride (PVC)
- ▶ Impervious to rot, decay and biological attack
- ▶ Flame spread rating of 5 per ASTM E84
- ▶ Elevated off of the cold water basin

## 9 Hygienic Cold Water Basin

- ▶ Sloped at the air intake face to eliminate stagnant water
- ▶ Sloped toward a depressed sump for easy cleaning

## 10 Two Large Access Doors (Not Shown)

- ▶ Inward hinged door on each end wall
- ▶ Easy safe access to the interior of the unit

# Series 3000 Custom Features & Options

## › Materials of Construction

Determining the appropriate material of construction for a project depends on several factors, including water quality, climate and environmental conditions, availability of time and manpower for maintenance, unit lifetime requirements, and budget. BAC provides the widest variety of material of construction options in the industry and has the ability to provide a solution to meet all conditions and budgets.



Standard Construction Installation



### STANDARD CONSTRUCTION

G-235 mill galvanized steel is the heaviest commercially available galvanized steel, universally recognized for its strength and corrosion resistance. To assure long-life, a G-235 mill galvanized steel frame with fiberglass reinforced polyester (FRP) casing panels and louvers is used as the standard material of construction. The structural integrity of the unit is provided by its strong steel frame. Series 3000 standard construction has been seismically verified by shake table testing in an independent laboratory up to an  $S_{DS}$  of 1.40g and can withstand wind loads of up to 2.85kPa, proving its frame construction is designed for extreme durability. With proper maintenance and water treatment, G-235 galvanized steel and FRP will provide an excellent service life under the operating conditions normally encountered in comfort cooling and industrial applications.



### STAINLESS STEEL (OPTION)

Several Type 304 stainless steel material of construction options are available.

- **WELDED TYPE 304 STAINLESS STEEL COLD WATER BASIN**

A Type 304 welded stainless steel cold water basin is available. All steel panels and structural members of the cold water basin are constructed from Type 304 stainless steel. Seams between panels inside the cold water basin are welded, providing an advantage over bolted stainless steel cold water basins for minimizing susceptibility to leaks at basin seams. The basin is leak tested at the factory and welded seams are provided with a 5-year, leak-proof warranty.

- **STAINLESS STEEL HOT WATER BASIN**

The hot water basin and basin covers are constructed of Type 304 stainless steel.



- **JE PREMIER SERIES®**

All unit structural elements and the hot and cold water basins are constructed of Type 304 stainless steel. Seams between panels inside the cold water basin are welded, providing an extreme advantage over bolted cold water basins for minimizing susceptibility to leaks at basin seams. The basin is leak tested at the factory and welded seams are provided with a 5-year leak-proof warranty. Casing panels and air intake louvers are constructed of corrosion and UV-resistant fiberglass reinforced polyester (FRP). Each cooling tower provided with the JE PREMIER SERIES® Construction is backed by a comprehensive Louvre-to-Louvre<sup>SM</sup> 5-year warranty, which covers ALL components from the fan to the cold water basin, from louver to louver, including the motor.

- ▶ **BASINLESS UNIT CONSTRUCTION (OPTION)**

The basinless unit construction option enables Series 3000 Cooling Towers to be directly installed on new or existing cold water basins. This custom feature reduces maintenance costs by eliminating the integral basin from traditional units. It simplifies piping and pumping requirements of multi-cell installations, eliminates concern for basin corrosion, and provides a cost-effective solution for many field-erected replacement projects. BAC is the only leading evaporative cooling equipment manufacturer to provide basinless construction for factory assembled equipment.



Welded Type 304 Stainless Steel Cold Water Basin



JE PREMIER SERIES® Construction



Basinless Construction

# Series 3000 Custom Features & Options

## ▶ SEISMIC/WIND UPGRADED STRUCTURE (OPTION)

Select steel panels and structural members are upgraded for higher seismic and wind load applications. An upgraded Series 3000 is certified to withstand up to an  $S_{DS}$  of 3.10g and wind loads of 3.9kPa. All BAC upgraded units are shake table tested by an independent laboratory to certify the most accurate seismic ratings ensuring that the unit will remain operable following a seismic event.

## ▶ STANDARD FIBERGLASS REINFORCED POLYESTER (FRP) CASING PANELS

Used with BAC's durable frame construction, FRP casing panels offer a more durable corrosion resistant unit. FRP casing panels are a key component due to their corrosion resistant properties.

## ▶ STEEL CASING PANELS AND LOUVERS (OPTION)

Steel casing panels and louvers are available in G-235 mill galvanized steel, thermosetting hybrid polymer, and stainless steel.



Seismic/Wind Upgraded Structure with Fiberglass Reinforced (FRP) Casing Panels



## > Drive System Options

The fan drive system provides the cooling air necessary to reject unwanted heat from the system to the atmosphere. All BAC drive systems use MEPS 2 compliant motors and include BAC's comprehensive 5-year motor and drive warranty. Cooling tower duty motors are specially designed for the harsh environment inside a cooling tower and have permanently lubricated bearings, drastically decreasing the maintenance requirement of the motor. BAC belt drive systems are the most durable and maintenance friendly drive systems on the market, including single nut adjustment for belt tensioning to make belt tensioning simple.



### STANDARD BALTIDRIVE® POWER TRAIN

The BALTIDRIVE® Power Train utilizes special corrosion resistant materials of construction and state-of-the-art technology to ensure ease of maintenance and reliable year-round performance. This BAC engineered drive system consists of a specially designed powerband and two cast aluminum sheaves located at minimal shaft centreline distances to maximize belt life. As compared to a gear drive system, this specially engineered belt drive system provides many advantages. The BALTIDRIVE® Power Train requires only periodic inspection of components and belt tensioning, which is simple with a single nut adjustment, and requires less downtime. Only fan bearing lubrication is required for routine maintenance. Belt drive systems also have the added advantage of being suitable for variable frequency drive (VFD) applications without requiring expensive optional accessories.



BALTIDRIVE® Power Train Fan System



### BALTIGUARD™ FAN SYSTEM (OPTION)

The BALTIGUARD™ Fan System consists of two standard single-speed fan motor and drive assemblies. One drive assembly is sized for full speed and load, and the other is sized approximately 2/3 speed and consumes only 1/3 the design horsepower. This configuration provides the reserve capability of a standby motor in the event of failure. As a minimum, approximately 70% capacity will be available from the low horsepower motor, even on a design wet-bulb day. Controls and wiring are the same as those required for a two-speed, two-winding motor. Redundant motors are available by increasing the size of the standby fan motor of the BALTIGUARD™ Fan System to the size of the main motor. This provides 100% motor redundancy and the greatest level of reliability.



BALTIGUARD™ Fan System Provides Built in Redundancy

# Series 3000 Custom Features & Options



## **BALTIGUARD PLUS™ FAN SYSTEM (OPTION)**

The BALTIGUARD PLUS™ Fan System builds on the advantages of the BALTIGUARD™ Fan System by adding a variable frequency drive (VFD) to either the pony or the main motor, depending on system requirements. This offers the benefits of additional capacity control and energy savings, along with the redundancy offered by the BALTIGUARD™ Fan System. Alternatively, a VFD can be added to both the pony and main motor for complete capacity control and redundancy under any load.

### ▶ **GEAR DRIVE SYSTEM, CLOSE-COUPLED MOTOR (OPTION, STANDARD ON S3E-1222-14T, S3E-1424-12T, S3E-1424-13T, AND S3E-1424-14T)**

A gear drive system is available as a fan drive option on the Series 3000. Both the gear drive and couplings are selected with a 2.0 service factor. Gear construction includes a nickel-alloy steel shaft, casehardened gears, self lubrication, and a single piece, gray iron housing. This drive system ships completely installed and aligned.

### ▶ **GEAR DRIVE SYSTEM, EXTERNALLY MOUNTED MOTOR (OPTION)**

A gear drive system with a TEFC motor mounted outside the airstream is also available on the Series 3000. A non-corrosive carbon-fiber composite drive shaft with stainless steel hubs is selected with a 2.0 service factor. The motor and drive shaft ship separately for easy field installation.

### ▶ **VIBRATION CUTOFF SWITCH (OPTION)**

A factory mounted vibration cutoff switch is available to effectively protect against rotating equipment failure. BAC can provide either a mechanical or solid-state electronic vibration cutoff switch in a NEMA 4 enclosure to ensure reliable protection. Additional contacts can be provided on either switch type to activate an alarm. Remote reset capability is also available on either switch type.

### ▶ **EXTENDED LUBRICATION LINES (OPTION)**

Extended lubrication lines are available for lubrication of the fan shaft bearings. Fittings are located on the exterior casing panel next to the access door.



BALTIGUARD PLUS™ Fan System  
Used for VFD Applications



Extended Lubrication Lines with  
Grease Fittings Located by the  
Access Door







## > Cold Water Basin

The cooling tower water collects in the cold water basin which provides the required head pressure for the cooling system pump. The Series 3000 cold water basin includes BAC's patented hygienic cold water basin design. During operation, BAC's patented hygienic cold water basin eliminates any stagnant water zones, which are susceptible to biological growth.

### ▶ STANDARD MECHANICAL WATER LEVEL CONTROL

Mechanical make-up valves must operate continuously in the moist and turbulent environment existing within evaporative cooling equipment. Due to this environment, the operation of the valve must be simple, and the valve must be durable. BAC's high quality mechanical water level control assembly is standard with all units, and has been specially designed to provide the most reliable operation while being easy to maintain. This accessory is omitted for remote sump applications.



Mechanical Water Level Control



### ELECTRIC WATER LEVEL CONTROL (OPTION)

BAC's Electric Water Level Control (EWLC) is a state-of-the-art conductivity actuated, probe type liquid level control. The hermetically sealed EWLC is engineered and manufactured specifically for use in evaporative cooling systems and is equipped with an error code LED which illuminates to indicate status, including when the water and/or probes are dirty. The EWLC option replaces the standard mechanical make-up valve, and includes a slow closing, solenoid activated valve in the make-up water line to minimize water hammer. EWLC is recommended when more precise water level control is required and in areas that experience sub-freezing conditions.

### ▶ SIDE OUTLET DEPRESSED SUMP BOX (OPTION)

A side outlet depressed sump box is available for field installation below the base of the tower. This option facilitates horizontal piping below the basin, and is a compact alternative to using an elbow in the piping arrangement, saving on both installation time and cost. The outlet connection is designed to mate with an ASME Class 150 flat face flange. See the "Connection Guide" for more information on standard and optional unit connection types.



Electric Water Level Control

# Series 3000 Custom Features & Options



## BASIN HEATERS (OPTION)

Evaporative cooling equipment exposed to below freezing ambient temperatures require protection to prevent freezing of the water in the cold water basin when the unit is idle. Factory-installed electric immersion heaters, which maintain 4.4°C water temperature, are a simple and inexpensive way of providing such protection.



Basin Heater

## HEATER kW DATA

Model Number	-17.8°C Ambient Heaters		-28.9°C Ambient Heaters	
	Number of Heaters	kW per Heater	Number of Heaters	kW per Heater
S3E/S3XE-8518	2	6	2	9
S3E/S3XE-1020	2	8	2	12
S3E/S3XE-1222-06x, 1222-07x	2	10	2	14
S3E/S3XE-1222-10x, 1222-12x, 1222-13x, 1222-14x	2	12	2	15
S3E/S3XE-1424-07x	2	14	2	18
S3E/S3XE-1424-12x, 1424-13x, 1424-14x	2	14	2	20



**NOTE:** This table is based on 415V/3 phase/50 Hz power.

- ▶ **STEAM COIL AND STEAM INJECTOR BASIN FREEZE PROTECTION (OPTION)**  
Steam coils and steam injectors are available to provide basin freeze protection.
- ▶ **BASIN SWEEPER PIPING (OPTION)**  
Basin sweeper piping is an effective method of reducing sediment that may collect in the cold water basin of the unit. A complete piping system, including nozzles, is provided in the cold water basin to connect to side stream filtration equipment (provided by others). For more information on filtration systems, consult "Filtration Guide" found.
- ▶ **LOW AND HIGH LEVEL ALARM FLOAT SWITCHES (OPTION)**  
Low and high level alarm float switches are available to provide added control to your equipment operation. Level alarms can alert operators to an abnormal operating condition to ensure the highest system efficiency with minimal water usage.

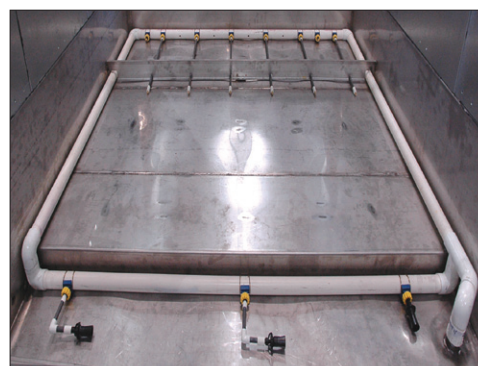

Basin Sweeper Piping



## > Multi-Cell Unit Options

Special care must be taken for multi-cell installations to ensure balanced water levels in the cold water basins across cells. If measures are not put in place to ensure balanced basin water levels, a potential exists that one basin may overflow and dump water, while the water level in another tower goes low and requires make-up. This leads to unnecessary water waste. To prevent this from occurring, BAC provides two options for balancing water levels and recommends that the installation be designed to ensure balanced flows to and from each tower.

### ▶ FLUME BOX – STANDARD ON ALL MULTI-CELL UNITS

A flume box is provided as standard for multi-cell units to balance the water level in the cold water basins. See the “Connection Guide” for more information.

### ▶ EQUALIZER (OPTION)

Equalizer connections are available as an option for multi-cell cooling towers in lieu of a flume box. Use of an equalizer allows for easy isolation of a cell for winter operation, maintenance, or inspection while continuing system operation. See “Cooling Towers in Parallel” for more information.

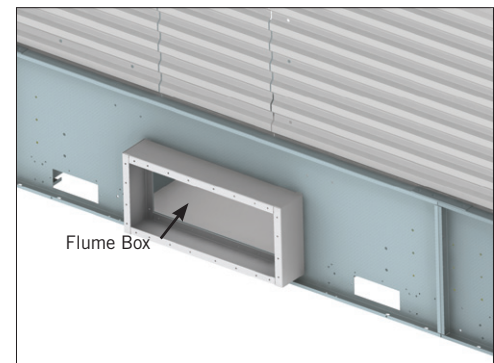

Flume Box

## > Water Distribution System

The Series 3000 Cooling Tower utilizes a low pump head gravity distribution system with large orifice non-clogging nozzles that requires less pump energy than a pressurized distribution system.

### ▶ STANDARD TOP INLET CONNECTIONS

The Series 3000 comes standard with top inlet connections to each of the hot water basins. Hot water basin covers matching the unit material of construction come in easy to handle sections for easy access and inspection of the distribution system. The use of gravity distribution minimizes pump head requirements and allows for maintenance during unit operation. BAC’s patented non-clog nozzles ensure even flow over the fill area and are simple to remove for maintenance.



Top Inlet Connections

# Series 3000 Custom Features & Options



## EASY CONNECT® PIPING ARRANGEMENT (OPTION)

The EASY CONNECT® Piping Arrangement simplifies water inlet piping on the Series 3000 by automatically balancing the flow within each cell, eliminating the need for flow balancing valves. A single water inlet connection, located on the side or bottom of each unit, eliminates the need for overhead piping and piping supports. It reduces installation costs and reduces potential for errors during field piping fabrication.



EASY CONNECT® Piping Arrangement

## STANDARD WEIR DAMS

Reducing water flow through a unit below the recommended level may potentially create uneven water distribution through the heat transfer section, causing scale build up, splash out/drift, and icing. To successfully modulate the water flow while avoiding potential complications, weir dams may be installed in the hot water basin. With a weir dam, the hot water basin can accommodate a flow range of 50% to 100% of the design flow.

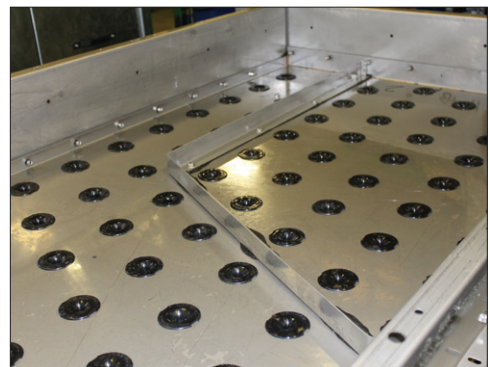

Weir Dams

## Fill

BACross® Fill, BAC's patented crossflow hanging fill, was developed after years of extensive research. BACross® Fill is made of PVC and is optimized to provide the most efficient thermal capacity. PVC is virtually impervious to rot, decay, and biological attack. The fill is elevated above the cold water basin floor to facilitate cleaning and maintenance. The integral eliminators effectively strip entrained moisture from the leaving air stream with minimum pressure drop to prevent water loss with negligible impact on efficiency.



BACross® Fill Manufacturing



## STANDARD FILL

Standard fill can be used in applications with entering water temperature up to 54.4°C. The fill and drift eliminators are formed from self-extinguishing PVC having a flame spread rating of 5 per ASTM E84.

## HIGH TEMPERATURE FILL (OPTION)

An optional high temperature fill material is available which increases the maximum allowable entering water temperature to 60°C.



## > Capacity Enhancement

The need to enhance the capacity of a unit may be necessary when layout is restricted or if capacity requirements have increased and exceed an existing unit's capabilities. By enhancing the capacity of a unit, it may be possible to use a smaller foot print while still meeting thermal requirements of the installation.

### ▶ VELOCITY RECOVERY (VR) STACKS (OPTION)

A VR stack is a conical fan cowl extension that reduces the discharge pressure the fan has to work against, allowing the fan to move more air for the same energy input. By moving more air through the same unit, the cooling capacity is increased without increasing horsepower or footprint. Effectively, the amount of energy required for each ton of cooling capacity is reduced. VR stacks are factory assembled, CTI certified, and can be configured during initial unit purchase to reduce energy requirements or through the aftermarket to increase capacity.



Velocity Recovery (VR) Stacks

## > Shipping and Rigging

BAC units are factory-assembled to ensure uniform quality with minimum field assembly. Each unit has been designed with rigging and assembly in mind and includes features to minimize the number of tools required and installation time.

### ▶ STANDARD RIGGING GUIDES

Rigging guides allow for the upper and lower section of units with a two piece rig to align and engage. The guides ensure proper placement of the top section for multi-cell installations, making rigging much simpler and reducing the time required. This is especially critical during multi-cell installations when units are rigged side-by-side.

### ▶ KNOCKDOWN UNITS (OPTION)

Knockdown units are available for jobs where access to the cooling tower location is limited by elevators, doorways, or similar obstacles, where lifting methods impose very strict weight limits, or where the shipping cost of a fully assembled tower is excessive. All materials of construction and design features are the same as those of a factory assembled unit. Welded Type 304 stainless steel cold water basins and TriArmor® Corrosion Protection System cold water basins are excluded due to the need for in-plant assembly.

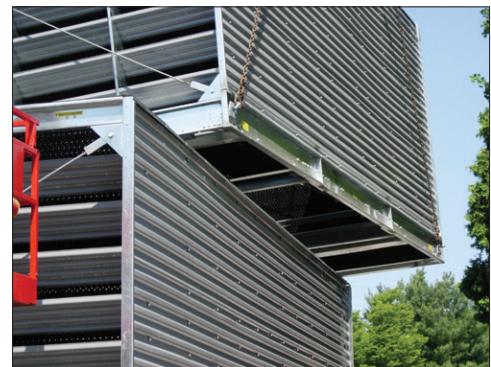

Rigging Guides Ensure Alignment



Knockdown Unit Installation

# Series 3000 Custom Features & Options

## > Sound Options

Recognition of the importance of sound reduction is growing and can be a very important design criterion for any project. BAC maintains the widest selection of sound mitigating options in the market place and can provide the most cost effective option to meet any requirement.



### STANDARD FAN

The fan provided for all Series 3000 Cooling Towers is selected to optimize low sound levels and maximize thermal performance.

### ▶ LOW SOUND FAN (OPTION)

The Low Sound Fan option reduces sound up to 9 dBA. Adding a high solidity fan decreases fan speeds, which proportionally decreases sound levels. The thermal performance with the Low Sound Fan has been certified in accordance with CTI Standard STD-201.

### ▶ WHISPER QUIET FAN (OPTION)

For the most extreme sound limitations, BAC's Whisper Quiet Fan is CTI-certified and reduces sound up to 19 dBA. The axial fan blades are constructed of high grade marine alloy aluminum for light weight construction and corrosion resistance. These heavy duty aluminum fans require minimal maintenance, making them well suited for use in cooling tower applications that benefit from extremely low sound operation.

### SOUND ATTENUATION (OPTION)

Factory designed, tested, and rated sound attenuation options are available for both the air intake and discharge. Consult your local BAC Representative regarding available options.

## > Air Intake Options

In a cooling tower, airborne debris can be entrained in the water through the unit's air intake. The Series 3000 has several options for air intake accessories that prevent debris from entering the system and maintain even unobstructed flow through the unit. Reducing the amount of debris that enters the tower lowers maintenance requirements and helps to maintain thermal efficiency.



Low Sound Fan



Whisper Quiet Fan



### COMBINED INLET SHIELDS (CIS)

The Combined Inlet Shields' (CIS) bent flow path blocks sunlight from the cold water basin and fill section and acts as a screen to prevent debris from entering the unit. These benefits result in a significant reduction in algae growth, debris accumulation, and scale build-up. CIS are constructed from corrosion and UV resistant PVC, are CTI certified, and are installed in easy to handle sections that are separate from the fill section to facilitate removal, inspection, and replacement. The use of CIS results in lower maintenance costs and ease of maintenance over the life of the unit.

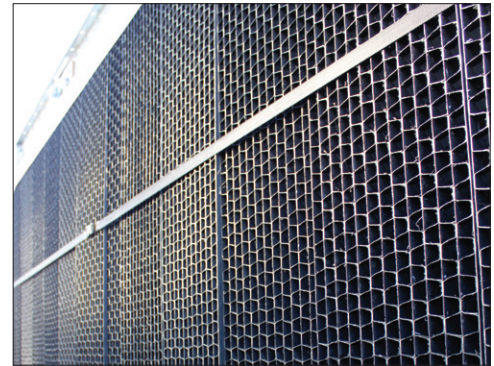

Combined Inlet Shields (CIS)

## > Access Options

BAC provides a broad offering of access options. Our evaporative equipment is designed to be the most easily maintained for sustaining capacity over a longer life. .

### ▶ MOTOR REMOVAL SYSTEM (OPTION)

All motor removal system options include modular davit arm(s) to facilitate motor replacement. There are three types of motor removal systems available on the Series 3000.



Motor Access Platform, and Handrail Package

# Series 3000 Custom Features & Options



**NOTE:** Platforms, ladders, handrails, safety gates, and safety cages can be added at the time of order or as an aftermarket item.



## EXTERNAL PLATFORMS AND LADDER PACKAGES (OPTION)

External platforms and ladder packages are available to provide safe access to key components of the unit for maintenance. Multiple configurations are available, including louver face platforms to gain access to the distribution system and motor access platforms for externally mounted gear drive motors.

## ACCESS DOOR PLATFORM AND LADDER PACKAGES (OPTION)

An access door platform is available to allow access to the unit when installed on elevated supports. This option allows for safe access to the unit, as well as a working platform to stage tools for maintenance.

## HANDRAIL PACKAGES (OPTION)

Handrail packages are available to provide safe access to the top of the unit for maintenance to the distribution system. Fan deck extensions are available for passage around the fan on units designed with maximized fan diameters, Velocity Recovery (VR) Stacks, or discharge sound attenuation. The specially designed handrail packages are secured for compact shipping in the cold water basin to minimize shipping costs and are ready for field assembly.



## INTERNAL WALKWAY (OPTION)

An internal walkway is available, allowing access to the spacious plenum area for maintenance and inspection of the cold water basin, make-up, fill, and drive system.

## INTERNAL SERVICE PLATFORM AND LADDER PACKAGES (OPTION FOR TWO PIECE UNITS)

For access to the motor and drive assemblies, an internal ladder and upper service platform with handrails is available on larger units. Safety gates are available for all handrail openings. An internal walkway is required with this package.



External Ladder and Platform



External Ladder, Safety Cage, and Handrail



Internal Ladder, Service Platform, and Walkway



# Series 3000 Engineering Data



**NOTE: Do not use for construction.** Refer to factory certified dimensions. This catalog includes data current at the time of publication, which should be reconfirmed at the time of purchase. Up-to-date engineering data, free product selection software, and more can be found at [www.BaltimoreAircoil.com](http://www.BaltimoreAircoil.com).

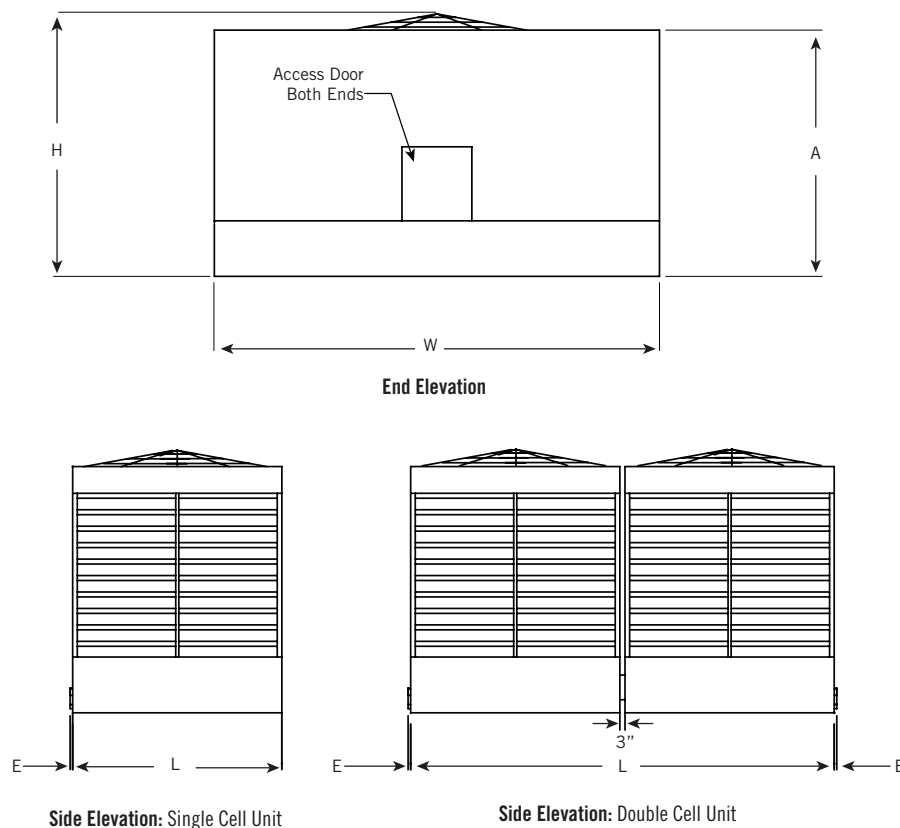

1. The E dimension represents the distance between the outer edge of the unit and the connection. For 2.5m, 3m, and 3.6m wide units this dimension is 300mm-35mm. The 4.2m wide units the E dimension is.

Note: The following units ship in two sections per cell. The top section is the heaviest and tallest. Top section heights are:

S3E Model	Catalog Upper Section With Installed Fan Guard Height (mm)	S3E Model	Catalog Upper Section With Installed Fan Guard Height (mm)
S3E-1222-10x	3124	S3E-1424-13x (L to Q)	3175
S3E-1222-12x	3124	S3E-1424-13 (R to S)	3327
S3E-1222-13x	3124	S3E-1424-13x (T)	3429
S3E-1222-14x	3531	S3E-1424-14x (M to Q)	3581
S3E-1424-12x (L to Q)	3175	S3E-1424-14x (R to S)	3327
S3E-1424-12x (R to S)	3327	S3E-1424-14x (T)	3835

# Series 3000 Single Cell Data

## SERIES 3000 UNITS

Model Number	Motor kW	Fan (m3/s)	Weights (kg)			Dimensions <sup>[3]</sup>			
			Operating <sup>[2]</sup>	Shipping	Heaviest Section	L	W	H <sup>[4]</sup>	A
S3E-8518-05L	11	36.5	6883	3643	3643	2591	5512	2997	1829
S3E-8518-05M	15	39.9	6910	3671	3671	2591	5512	2997	1829
S3E-8518-06L	11	39.7	7273	3793	3793	2591	5512	3404	3048
S3E-8518-06M	15	43.4	7282	3802	3802	2591	5512	3404	3048
S3E-8518-06N	18.5	46.4	7296	3816	3816	2591	5512	3404	3048
S3E-8518-06O	22	49.1	7319	3838	3838	2591	5512	3404	3048
S3E-8518-07M	15	46.7	8317	3975	3975	2591	5512	3810	3454
S3E-8518-07N	18.5	50.0	8330	3988	3988	2591	5512	3810	3454
S3E-8518-07O	22	52.8	8353	4011	4011	2591	5512	3810	3454
S3E-8518-07P	30	57.5	8426	4083	4083	2591	5512	3810	3454
S3E-1020-06M	15	46.2	8684	4328	4328	2997	6121	3302	3048
S3E-1020-06N	18.5	49.4	8748	4392	4392	2997	6121	3302	3048
S3E-1020-06O	22	52.3	8770	4415	4415	2997	6121	3302	3048
S3E-1020-07M	15	49.9	9156	4487	4487	2997	6121	3708	3454
S3E-1020-07N	18.5	53.4	9220	4551	4551	2997	6121	3708	3454
S3E-1020-07O	22	56.4	9242	4574	4574	2997	6121	3708	3454
S3E-1020-07P	30	61.6	9315	4646	4646	2997	6121	3708	3454
S3E-1222-06M	15	53.0	10735	5163	5163	3607	6579	3327	3048
S3E-1222-06N	18.5	56.7	10799	5227	5227	3607	6579	3327	3048
S3E-1222-06O	22	60.0	10821	5250	5250	3607	6579	3327	3048
S3E-1222-07N	18.5	61.4	11411	5499	5499	3607	6579	3734	3454
S3E-1222-07O	22	64.9	11434	5522	5522	3607	6579	3734	3454
S3E-1222-07P	30	70.7	11506	5594	5594	3607	6579	3734	3454
S3E-1222-07Q	37	75.6	11511	5599	5599	3607	6579	3734	3454
S3E-1222-07R	45	79.9	11856	5944	5944	3607	6579	3734	3454
S3E-1222-10P	30	85.2	15204	6956	4088	3607	6579	5004	4724
S3E-1222-10Q	37	90.9	15277	7028	4161	3607	6579	5004	4724
S3E-1222-10R	45	95.8	15281	7033	4165	3607	6579	5004	4724
S3E-1222-10S	55	102.2	15717	7468	4601	3607	6579	5004	4724
S3E-1222-12P	30	90.4	16447	7377	4138	3607	6579	5817	5537
S3E-1222-12Q	37	96.4	16475	7405	4165	3607	6579	5817	5537
S3E-1222-12R	45	101.6	16570	7500	4260	3607	6579	5817	5537
S3E-1222-12S	55	108.3	17005	7936	4696	3607	6579	5817	5537
S3E-1222-13P	30	93.0	16865	7586	4138	3607	6579	6223	5944
S3E-1222-13Q	37	99.1	16892	7613	4165	3607	6579	6223	5944
S3E-1222-13R	45	104.4	16987	7709	4260	3607	6579	6223	5944
S3E-1222-13S	55	111.3	17024	7745	4297	3607	6579	6223	5944



**NOTE: Do not use for construction.** Refer to factory certified dimensions. This catalog includes data current at the time of publication, which should be reconfirmed at the time of purchase. Up-to-date engineering data, free product selection software, and more can be found at [www.Baltimoreaircoil.com.au](http://www.Baltimoreaircoil.com.au).

## SERIES 3000 UNITS

Model Number	Motor HP	Fan (m3/s)	Weights (kg)			Dimensions <sup>(4)</sup>			
			Operating <sup>(2)</sup>	Shipping	Heaviest Section	L	W	H <sup>(3)</sup>	A
S3E-1222-14P	40	96.2	17055	7781	4356	3607	6579	6629	6350
S3E-1222-14Q	50	102.6	17083	7809	4383	3607	6579	6629	6350
S3E-1222-14R	60	108.1	17155	7881	4456	3607	6579	6629	6350
S3E-1222-14S	75	115.2	17191	7917	4492	3607	6579	6629	6350
S3E-1222-14T	100	125.1	18063	8789	4986	3607	6579	6629	6350
S3E-1424-07O	30	72.8	15653	7468	7468	4267	7341	3759	3454
S3E-1424-07P	40	79.4	15726	7541	7541	4267	7341	3759	3454
S3E-1424-07Q	50	84.9	15730	7545	7545	4267	7341	3759	3454
S3E-1424-07R	60	89.7	15735	7550	7550	4267	7341	3759	3454
S3E-1424-12Q	50	110.6	20181	9819	5399	4267	7341	5867	5537
S3E-1424-12R	60	116.5	20254	9891	5472	4267	7341	6070	5537
S3E-1424-12S	75	124.1	20277	9914	5495	4267	7341	6070	5537
S3E-1424-12T	100	131.9	21148	10785	5989	4267	7341	6121	5537
S3E-1424-13Q	50	114.0	20808	9995	5399	4267	7341	6274	5994
S3E-1424-13R	60	120.0	20880	10068	5472	4267	7341	6426	5994
S3E-1424-13S	75	127.8	20903	10091	5495	4267	7341	6426	5994
S3E-1424-13T	100	135.9	21774	10962	5989	4267	7341	6528	5994
S3E-1424-14Q	50	118.4	21525	10172	5740	4267	7341	6680	6350
S3E-1424-14R	60	124.6	21597	10245	5812	4267	7341	6833	6350
S3E-1424-14S	75	132.6	21620	10268	5835	4267	7341	6833	6350
S3E-1424-14T	100	140.9	22491	11139	6329	4267	7341	6934	6350



### NOTES FOR SINGLE CELL UNITS:

1. S3E-1222-14T, S3E-1424-12T, S3E-1424-13T and S3E-1424-14T are supplied with a gear drive system as standard.
2. Operating weight is based on the water level in the cold water basin at overflow height. If a lower operating weight is needed to meet design requirements, your local BAC Representative can provide additional assistance.
3. Refer to **page 24** for dimensional reference drawings.
4. Models shipped with an optional gear drive or Low Sound Fan may have heights up to 270mm greater than shown. For units with Whisper Quiet Fans please contact your local BAC Representative for height dimensions.

# XE-Series Data

## XE-SERIES UNITS

Model Number	Motor HP	Fan (m3/s)	Weights (kg)			Dimensions <sup>(4)</sup>			
			Operating <sup>(3)</sup>	Shipping	Heaviest Section	L	W	H <sup>(5)</sup>	A
XES3E-8518-05G	2.2	22.1	6806	3566	3566	2590	5512	2997	2692
XES3E-8518-05H	4	25.9	6810	3571	3571	2590	5512	2997	2692
XES3E-8518-05J	5.5	29.4	6824	3584	3584	2590	5512	2997	2692
XES3E-8518-05K	7.5	32.2	6828	3589	3589	2590	5512	2997	2692
XES3E-8518-06G	2.2	24.2	7219	3739	3739	2590	5512	3404	3048
XES3E-8518-06H	4	28.3	7223	3743	3743	2590	5512	3404	3048
XES3E-8518-06J	5.5	32.1	7237	3757	3757	2590	5512	3404	3048
XES3E-8518-06K	7.5	35.1	7241	3761	3761	2590	5512	3404	3048
XES3E-8518-07G	2.2	26.2	8253	3911	3911	2590	5512	3810	3454
XES3E-8518-07H	4	30.7	8258	3916	3916	2590	5512	3810	3454
XES3E-8518-07J	5.5	34.7	8271	3929	3929	2590	5512	3810	3454
XES3E-8518-07K	7.5	37.9	8276	3934	3934	2590	5512	3810	3454
XES3E-8518-07L	11	42.8	8308	3966	3966	2590	5512	3810	3454
XES3E-1020-06G	2.2	25.8	8630	4274	4274	2997	6121	3302	3048
XES3E-1020-06H	4	30.2	8634	4279	4279	2997	6121	3302	3048
XES3E-1020-06J	5.5	34.2	8639	4283	4283	2997	6121	3302	3048
XES3E-1020-06K	7.5	37.4	8643	4288	4288	2997	6121	3302	3048
XES3E-1020-06L	11	42.3	8675	4319	4319	2997	6121	3302	3048
XES3E-1020-07G	2.2	27.9	9093	4424	4424	2997	6121	3708	3454
XES3E-1020-07H	4	32.7	9097	4428	4428	2997	6121	3708	3454
XES3E-1020-07J	5.5	37.0	9111	4442	4442	2997	6121	3708	3454
XES3E-1020-07K	7.5	40.4	9115	4446	4446	2997	6121	3708	3454
XES3E-1020-07L	11	45.8	9601	4478	4478	2997	6121	3708	3454
XES3E-1222-06H	4	34.6	10676	5104	5104	3607	6579	3327	3048
XES3E-1222-06J	5.5	39.3	10690	5118	5118	3607	6579	3327	3048
XES3E-1222-06K	7.5	42.9	10694	5123	5123	3607	6579	3327	3048
XES3E-1222-06L	11	48.5	10726	5154	5154	3607	6579	3327	3048
XES3E-1222-07J	5.5	42.5	11302	5390	5390	3607	6579	3734	3454
XES3E-1222-07K	7.5	46.4	11307	5395	5395	3607	6579	3734	3454
XES3E-1222-07L	11	52.6	11338	5426	5426	3607	6579	3734	3454
XES3E-1222-07M	15	57.4	11348	5436	5436	3607	6579	3734	3454
XES3E-1222-10K	7.5	56.6	15014	6765	3897	3607	6579	5004	4724
XES3E-1222-10L	11	63.9	15045	6797	3929	3607	6579	5004	4724
XES3E-1222-10M	15	69.6	15054	6806	3938	3607	6579	5004	4724
XES3E-1222-10N	18.5	74.3	15118	6869	4002	3607	6579	5004	4724
XES3E-1222-10O	22	78.3	15141	6892	4025	3607	6579	5004	4724
XES3E-1222-12K	7.5	60.3	16257	7187	3947	3607	6579	5817	5537
XES3E-1222-12L	11	68.0	16289	7219	3979	3607	6579	5817	5537
XES3E-1222-12M	15	74.0	16298	7228	3988	3607	6579	5817	5537
XES3E-1222-12N	18.5	78.9	16361	7291	4052	3607	6579	5817	5537
XES3E-1222-12O	22	83.2	16384	7314	4074	3607	6579	5817	5537



**NOTE: Do not use for construction.** Refer to factory certified dimensions. This catalog includes data current at the time of publication, which should be reconfirmed at the time of purchase. Up-to-date engineering data, free product selection software, and more can be found at [www.Baltimoreaircoil.com.au](http://www.Baltimoreaircoil.com.au).

## XE-SERIES UNITS

Model Number	Motor HP	Fan (m3/s)	Weights (kg)			Dimensions <sup>[3]</sup>			
			Operating <sup>[2]</sup>	Shipping	Heaviest Section	L	W	H <sup>[4]</sup>	A
XES3E-1222-13K	7.5	62.1	16674	7396	3947	3607	6579	6223	5944
XES3E-1222-13L	11	70.0	16706	7427	3979	3607	6579	6223	5944
XES3E-1222-13M	15	76.1	16715	7436	3988	3607	6579	6223	5944
XES3E-1222-13N	18.5	81.2	16779	7500	4052	3607	6579	6223	5944
XES3E-1222-13O	22	85.6	16801	7523	4074	3607	6579	6223	5944
XES3E-1222-14L	11	72.5	16897	7623	4197	3607	6579	6629	6350
XES3E-1222-14M	15	78.8	16909	7632	4206	3607	6579	6629	6350
XES3E-1222-14N	18.5	84.1	16969	7695	4270	3607	6579	6629	6350
XES3E-1222-14O	22	88.6	16992	7718	4292	3607	6579	6629	6350
XES3E-1424-07J	5.5	47.7	15522	7337	7337	4267	7341	3759	3454
XES3E-1424-07K	7.5	52.1	15526	7341	7341	4267	7341	3759	3454"
XES3E-1424-07L	11	59.0	15558	7373	7373	4267	7341	3759	3454
XES3E-1424-07M	15	64.4	15567	7382	7382	4267	7341	3759	3454
XES3E-1424-07N	18.5	68.9	15631	7446	7446	4267	7341	3759	3454
XES3E-1424-12L	11	78.4	19995	9632	5213	4267	7341	5867	5537
XES3E-1424-12M	15	85.2	20005	9642	5222	4267	7341	5867	5537
XES3E-1424-12N	18.5	90.8	20068	9705	5286	4267	7341	5867	5537
XES3E-1424-12O	22	95.7	20091	9728	5309	4267	7341	5867	5537
XES3E-1424-12P	30	103.8	20154	9791	5372	4267	7341	5867	5537"
XES3E-1424-13L	11	81.0	20622	9809	5213	4267	7341	6274	5944
XES3E-1424-13M	15	88.0	20631	9819	5222	4267	7341	6274	5944
XES3E-1424-13N	18.5	93.7	20694	9882	5286	4267	7341	6274	5944
XES3E-1424-13O	22	98.7	20717	9905	5309	4267	7341	6274	5944
XES3E-1424-13P	30	107.1	20780	97536	5372	4267	7341	6274	5944
XES3E-1424-14M	15	91.4	21348	9995	5563	4267	7341	6680	6350
XES3E-1424-14N	18.5	97.4	21411	10059	5626	4267	7341	6680	6350
XES3E-1424-14O	22	102.5	21434	10082	5649	4267	7341	6680	6350
XES3E-1424-14P	30	111.2	21497	10145	5712	4267	7341	6680	6350



### NOTES FOR XE-SERIES UNITS:

1. Operating weight is based on the water level in the cold water basin at overflow height. If a lower operating weight is needed to meet design requirements, your local BAC Representative can provide additional assistance.
2. Refer to **page 24** for dimensional reference drawings.
3. Models shipped with an optional gear drive or Low Sound Fan may have heights up to 270mm greater than shown. For units with Whisper Quiet Fans please contact your local BAC Representative for height dimensions.

# Series 3000 Double Cell Units

## DOUBLE CELL SERIES 3000 UNITS

Model Number	Motor kW	Fan (m <sup>3</sup> /s)	Weights (kg)			Dimensions <sup>[3]</sup>			
			Operating <sup>[2]</sup>	Shipping	Heaviest Section	L	W	H <sup>[4]</sup>	A
S3E-8518-05L-2	11	36.5	6883	3643	3643	5258	5512	2997	1829
S3E-8518-05M-2	15	39.9	6910	3671	3671	5258	5512	2997	1829
S3E-8518-06L-2	11	39.7	7273	3793	3793	5258	5512	3404	3048
S3E-8518-06M-2	15	43.4	7282	3802	3802	5258	5512	3404	3048
S3E-8518-06N-2	18.5	46.4	7296	3816	3816	5258	5512	3404	3048
S3E-8518-06O-2	22	49.1	7319	3838	3838	5258	5512	3404	3048
S3E-8518-07M-2	15	46.7	8317	3975	3975	5258	5512	3810	3454
S3E-8518-07N-2	18.5	50.0	8330	3988	3988	5258	5512	3810	3454
S3E-8518-07O-2	22	52.8	8353	4011	4011	5258	5512	3810	3454
S3E-8518-07P-2	30	57.5	8426	4083	4083	5258	5512	3810	3454
S3E-1020-06M-2	15	46.2	8684	4328	4328	6045	6121	3302	3048
S3E-1020-06N-2	18.5	49.4	8748	4392	4392	6045	6121	3302	3048
S3E-1020-06O-2	22	52.3	8770	4415	4415	6045	6121	3302	3048
S3E-1020-07M-2	15	49.9	9156	4487	4487	6045	6121	3708	3454
S3E-1020-07N-2	18.5	53.4	9220	4551	4551	6045	6121	3708	3454
S3E-1020-07O-2	22	56.4	9242	4574	4574	6045	6121	3708	3454
S3E-1020-07P-2	30	61.6	9315	4646	4646	6045	6121	3708	3454
S3E-1222-06M-2	15	53.0	10735	5163	5163	7290	6579	3327	3048
S3E-1222-06N-2	18.5	56.7	10799	5227	5227	7290	6579	3327	3048
S3E-1222-06O-2	22	60.0	10821	5250	5250	7290	6579	3327	3048
S3E-1222-07N-2	18.5	61.4	11411	5499	5499	7290	6579	3734	3454
S3E-1222-07O-2	22	64.9	11434	5522	5522	7290	6579	3734	3454
S3E-1222-07P-2	30	70.7	11506	5594	5594	7290	6579	3734	3454
S3E-1222-07Q-2	37	75.6	11511	5599	5599	7290	6579	3734	3454
S3E-1222-07R-2	45	79.9	11856	5944	5944	7290	6579	3734	3454
S3E-1222-10P-2	30	85.2	15204	6956	4088	7290	6579	5004	4724
S3E-1222-10Q-2	37	90.9	15277	7028	4161	7290	6579	5004	4724
S3E-1222-10R-2	45	95.8	15281	7033	4165	7290	6579	5004	4724
S3E-1222-10S-2	55	102.2	15717	7468	4601	7290	6579	5004	4724
S3E-1222-12P-2	30	90.4	16447	7377	4138	7290	6579	5817	5537
S3E-1222-12Q-2	37	96.4	16475	7405	4165	7290	6579	5817	5537
S3E-1222-12R-2	45	101.6	16570	7500	4260	7290	6579	5817	5537
S3E-1222-12S-2	55	108.3	17005	7936	4696	7290	6579	5817	5537
S3E-1222-13P-2	30	93.0	16865	7586	4138	7290	6579	6223	5944
S3E-1222-13Q-2	37	99.1	16892	7613	4165	7290	6579	6223	5944
S3E-1222-13R-2	45	104.4	16987	7709	4260	7290	6579	6223	5944
S3E-1222-13S-2	55	111.3	17024	7745	4297	7290	6579	6223	5944



**NOTE: Do not use for construction.** Refer to factory certified dimensions. This catalog includes data current at the time of publication, which should be reconfirmed at the time of purchase. Up-to-date engineering data, free product selection software, and more can be found at [www.Baltimoreaircoil.com.au](http://www.Baltimoreaircoil.com.au).

## DOUBLE CELL SERIES 3000 UNITS

Model Number	Motor HP	Fan (m3/s)	Weights (kg)			Dimensions <sup>(4)</sup>			
			Operating <sup>(2)</sup>	Shipping	Heaviest Section	L	W	H <sup>(3)</sup>	A
S3E-1222-14P-2	40	96.2	17055	7781	4356	7290	6579	6629	6350
S3E-1222-14Q-2	50	102.6	17083	7809	4383	7290	6579	6629	6350
S3E-1222-14R-2	60	108.1	17155	7881	4456	7290	6579	6629	6350
S3E-1222-14S-2	75	115.2	17191	7917	4492	7290	6579	6629	6350
S3E-1222-14T-2	100	125.1	18063	8789	4986	7290	6579	6629	6350
S3E-1424-070-2	30	72.8	15653	7468	7468	8585	7341	3759	3454
S3E-1424-07P-2	40	79.4	15726	7541	7541	8585	7341	3759	3454
S3E-1424-07Q-2	50	84.9	15730	7545	7545	8585	7341	3759	3454
S3E-1424-07R-2	60	89.7	15735	7550	7550	8585	7341	3759	3454
S3E-1424-12Q-2	50	110.6	20181	9819	5399	8585	7341	5867	5537
S3E-1424-12R-2	60	116.5	20254	9891	5472	8585	7341	6070	5537
S3E-1424-12S-2	75	124.1	20277	9914	5495	8585	7341	6070	5537
S3E-1424-12T-2	100	131.9	21148	10785	5989	8585	7341	6121	5537
S3E-1424-13Q-2	50	114.0	20808	9995	5399	8585	7341	6274	5994
S3E-1424-13R-2	60	120.0	20880	10068	5472	8585	7341	6426	5994
S3E-1424-13S-2	75	127.8	20903	10091	5495	8585	7341	6426	5994
S3E-1424-13T-2	100	135.9	21774	10962	5989	8585	7341	6528	5994
S3E-1424-14Q-2	50	118.4	21525	10172	5740	8585	7341	6680	6350
S3E-1424-14R-2	60	124.6	21597	10245	5812	8585	7341	6833	6350
S3E-1424-14S-2	75	132.6	21620	10268	5835	8585	7341	6833	6350
S3E-1424-14T-2	100	140.9	22491	11139	6329	8585	7341	6934	6350



### NOTES FOR DOUBLE CELL UNITS:

1. S3E-1222-14T, S3E-1424-12T, S3E-1424-13T and S3E-1424-14T are supplied with a gear drive system as standard.
2. Operating weight is based on the water level in the cold water basin at overflow height. If a lower operating weight is needed to meet design requirements, your local BAC Representative can provide additional assistance.
3. Refer to **page 24** for dimensional reference drawings.
4. Models shipped with an optional gear drive or Low Sound Fan may have heights up to 270mm greater than shown. For units with Whisper Quiet Fans please contact your local BAC Representative for height dimensions.

# Series 3000 Connection Data

## CONNECTION DIMENSIONS

Model Number	Dimensions <sup>[1]</sup>				Inlet Connection Sizes <sup>[2,4]</sup>		Outlet Connection Sizes <sup>[3,4]</sup>	
	B	C	D	F	Easy Connect	Top Inlet	Outlet	Remote Sump
S3E/XES3E-8518-05x	1753	1143	229	1981	203	152	203	254
S3E/XES3E-8518-06x	2007	1143	229	1981	203	152	203	254
S3E/XES3E-8518-07x	2007	1143	254	1981	254	203	254	305
S3E/XES3E-1020-06x	2007	1143	254	2057	254	203	254	305
S3E/XES3E-1020-07x	2007	1143	254	2057	254	203	254	305
S3E/XES3E-1222-06x	2007	1219	254	2642	254	203	254	305
S3E/XES3E-1222-07x	2007	1219	254	2642	254	203	254	356
S3E/XES3E-1222-10x	3175	1219	254	2642	305	203	305	406
S3E/XES3E-1222-12x	3988	1219	254	2642	305	203	305	406
S3E/XES3E-1222-13x	4394	1219	254	2642	305	203	305	457
S3E/XES3E-1222-14x	4801	1219	254	2642	356	254	356	508
S3E/XES3E-1424-07x	2007	1245	254	2692	305	203	305	406
S3E/XES3E-1424-12x	3988	1245	254	2692	356	254	356	508
S3E/XES3E-1424-13x	4394	1245	254	2692	356	254	356	508
S3E/XES3E-1424-14x	4801	1245	254	2692	356	254	356	508



### NOTES FOR CONNECTION DIMENSIONS:

1. For dimension locations, see **page 32**.
2. The specific size of the inlet and outlet connection may vary with the design cooling water flow rate.
3. Unless otherwise indicated, all connections 80NB and smaller are male pipe thread, and connections 100NB and larger are beveled for welding and grooved to suit a mechanical coupling.
4. On double cell units, connections are the same size but are located on both ends of the unit. Refer to **page 24** for side elevation view.





**NOTE: Do not use for construction.** Refer to factory certified dimensions. This catalog includes data current at the time of publication, which should be confirmed at the time of purchase. Up-to-date engineering data, free product selection software, and more can be found at [www.Baltimoreaircoil.com.au](http://www.Baltimoreaircoil.com.au).

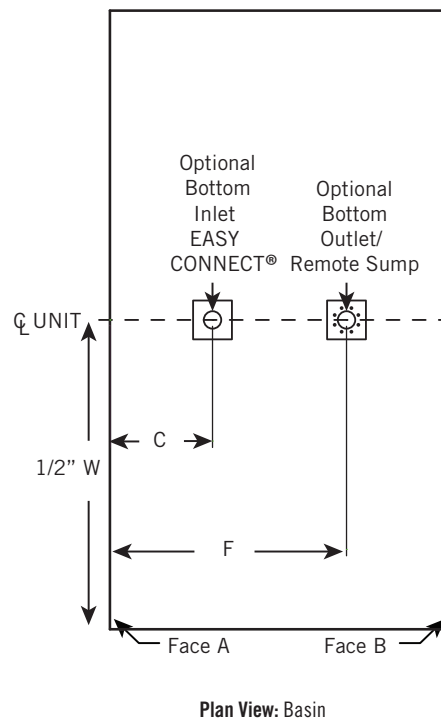
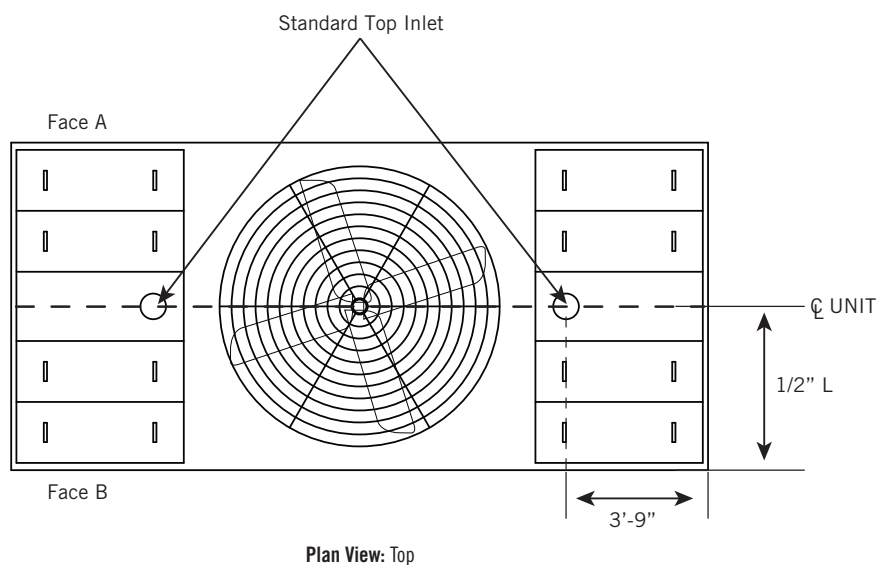
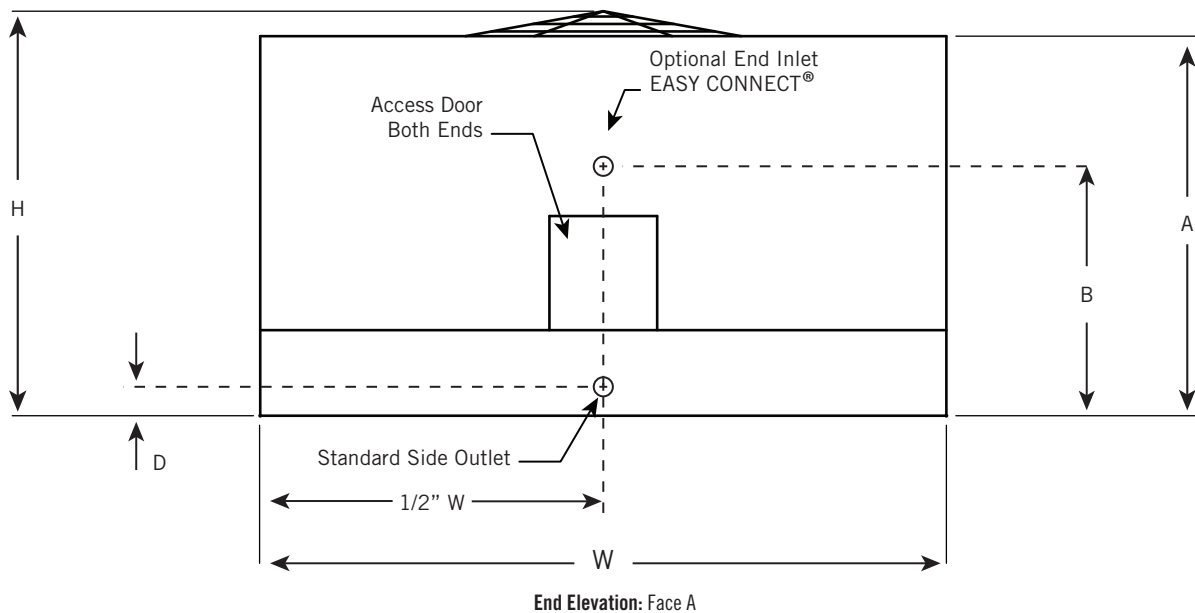

# Series 3000 Basinless Data

## CONCRETE BASIN ENGINEERING DATA FOR OPTIONAL BASINLESS UNITS

Model Number	Operating Load Vertical (kg)	Maximum Operating Weight (kg)	A	B	C	D
S3E/XES3E-8518-05x	830	4980	2760	5600	2800	-
S3E/XES3E-8518-06x	900	5390	2760	5600	2800	-
S3E/XES3E-8518-07x	1080	6495	2760	5600	2800	-
S3E/XES3E-1020-06x	1065	6380	3180	5600	3110	-
S3E/XES3E-1020-07x	1150	6925	3180	5600	3110	-
S3E/XES3E-1222-06x	1270	7595	3800	6670	3330	-
S3E/XES3E-1222-07x	1440	8630	3800	6670	3330	-
S3E/XES3E-1222-10x	2020	12105	3800	6670	3330	-
S3E/XES3E-1222-12x	2235	13395	3800	6670	3330	-
S3E/XES3E-1222-13x	2235	13410	3800	6670	3330	-
S3E/XES3E-1222-14x	2410	14455	3800	6670	3330	-
S3E/XES3E-1424-07x	1370	10935	4450	7430	2340	2740
S3E/XES3E-1424-12x	2080	16590	4450	7430	2340	2740
S3E/XES3E-1424-13x	2150	17210	4450	7430	2340	2740
S3E/XES3E-1424-14x	2245	17930	4450	7430	2340	2740



### NOTES FOR BASINLESS DATA:

1. Purchaser to design, construct, and furnish basin (including anchor bolts) in accordance with requirements given. Purchaser must also supply sump, overflow, drain, cleanout, and water make-up to suit requirements.
2. All anchor bolts shall be 19mm diameter, 38mm projection ( $\pm 1/4"$ ), fully threaded. Bolt to have one nut and washer. Anchor bolt and column bearing point locations and elevations must be maintained  $\pm 3$ mm.
3. Pier dimensions shown are minimum bearing surfaces required for the tower structure and do not include corner chamfers on the concrete piers.
4. Fill to be located below the operating water level (see Side View of Concrete Basin for All Models on **page 34**).
5. Maximum operating weight does not include concrete basin or water retained in the basin.



**NOTE: Do not use for construction.** Refer to factory certified dimensions. This catalog includes data current at the time of publication, which should be reconfirmed at the time of purchase. Up-to-date engineering data, free product selection software, and more can be found at [www.Baltimoreaircoil.com.au](http://www.Baltimoreaircoil.com.au).

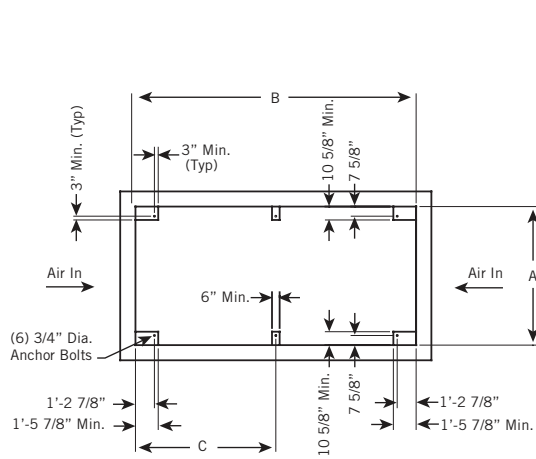

**Plan View of Concrete Basin:**

Models S3E/XES3E-8518-X, S3E/XES3E-1020-X, and S3E/XES3E-1222-X

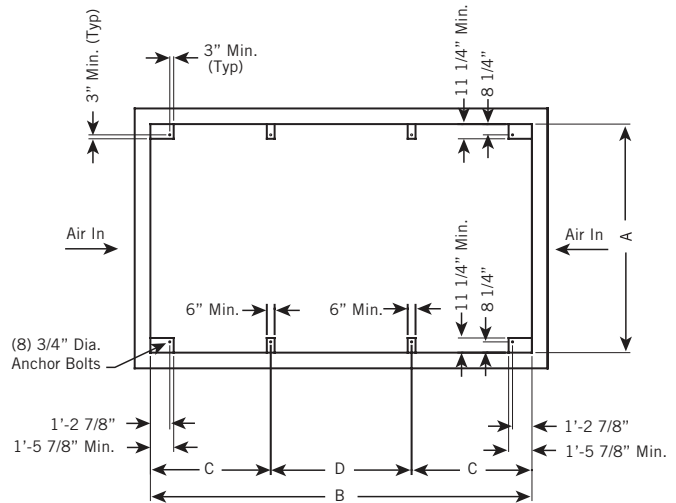

**Plan View of Concrete Basin:**

Model S3E/XES3E-1424-X

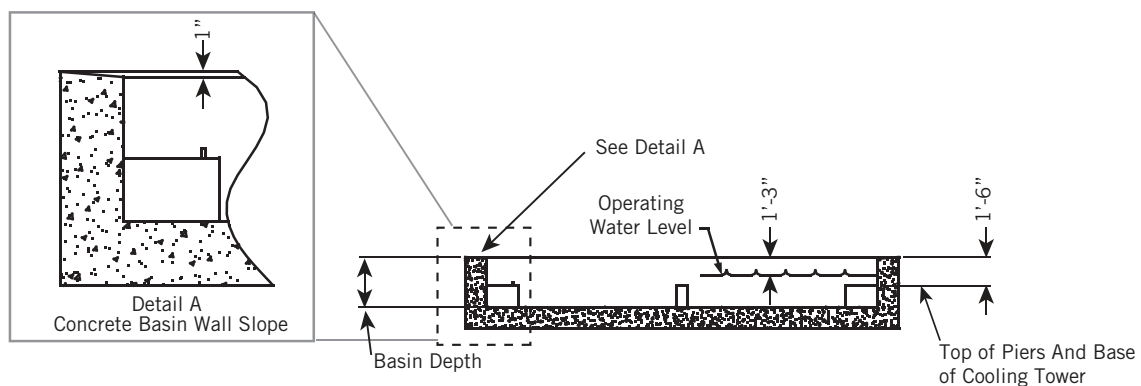

**Side View of Concrete Basin: All Models**

# Series 3000 Structural Support

The recommended support arrangement for the Series 3000 Cooling Tower consists of parallel I-beams positioned as shown in the drawings on **page 36**. Besides providing adequate support, the steel also serves to raise the unit above any solid foundation to assure access to the bottom of the tower. The Series 3000 Cooling Tower may also be supported on columns at the anchor bolt locations shown in Plan A (single cell) or Plan C (double cell). A minimum bearing surface of 305mm x 305mm must be provided under each of the concentrated load points. Alternate steel support arrangements can be found on **page 37**. To support a Series 3000 Cooling Tower on columns with an alternate steel support arrangement or the optional upgraded seismic and wind rated unit, consult your local BAC Representative.

## STRUCTURAL SUPPORT

Model Number	Weights (kgs)			Dimensions (mm)						
	Operating <sup>(1)</sup>	Shipping <sup>(2)</sup>	WT. at Bolt Hole Locations	L1	L2	W	A	B	C	D
S3E/XES3E-8518-05x	6908	3670	830	2586	5231	5503	2842	29	2529	121
S3E/XES3E-8518-06x	7316	3837	902	2586	5231	5503	2842	29	2529	121
S3E/XES3E-8518-07x	8423	4082	1084	2586	5231	5503	2842	29	2529	121
S3E/XES3E-1020-06x	8768	4413	1066	2975	6019	6113	3452	29	2918	121
S3E/XES3E-1020-07x	9312	4645	1157	2975	6019	6113	3452	29	2918	121
S3E/XES3E-1222-06x	10818	5248	1270	3598	7264	6565	3914	29	3540	121
S3E/XES3E-1222-07x	11852	5942	1442	3598	7264	6565	3914	29	3540	121
S3E/XES3E-1222-10x	15712	7466	2018	3598	7264	6565	3914	29	3540	121
S3E/XES3E-1222-12x	17000	7933	2236	3600	7264	6565	3914	29	3540	121
S3E/XES3E-1222-13x	17019	7743	2236	3598	7264	6565	3914	29	3540	121
S3E/XES3E-1222-14x	18057	8786	2413	3598	7264	6565	3914	29	3540	121
S3E/XES3E-1424-07x	15730	7548	1370	4243	8549	7333	4672	37	4170	137
S3E/XES3E-1424-12x	21142	10781	2077	4243	8549	7333	4672	37	4170	137
S3E/XES3E-1424-13x	21768	10959	2155	4243	8549	7333	4672	37	4170	137
S3E/XES3E-1424-14x	22485	11136	2245	4243	8549	7333	4672	37	4170	137



### NOTES:

1. Operating weight is based on the water level in cold water basin at overflow height.
2. Unit support beams and anchor bolts to be designed and furnished by others.
3. Support beams must be flush and level at top.
4. Steel frame members perpendicular to the support beams and under the air intake edges of unit must be at least 50mm below the top of the support beams.
5. For support beam spacing other than shown, mounting holes in the unit are to be drilled by others.

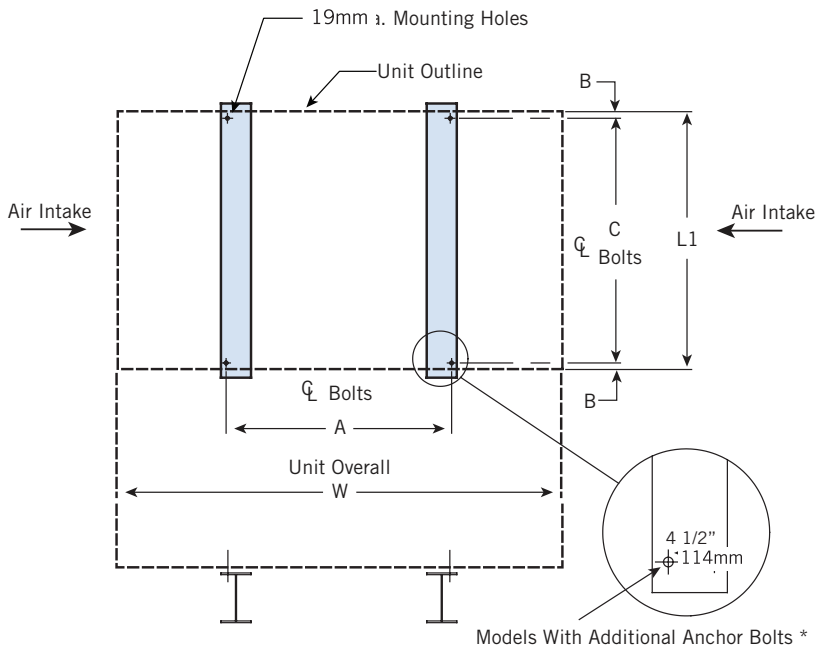

Plan A: Single Cell Unit

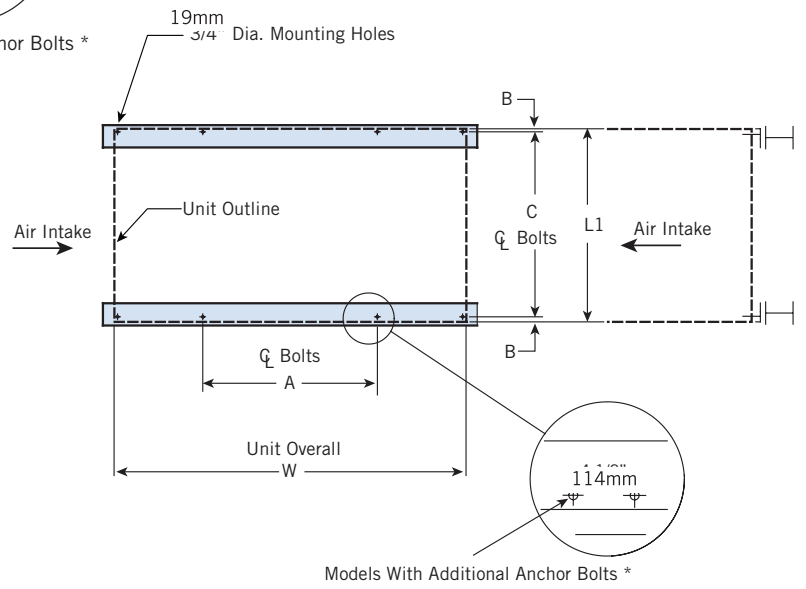

Plan B: Single Cell Unit

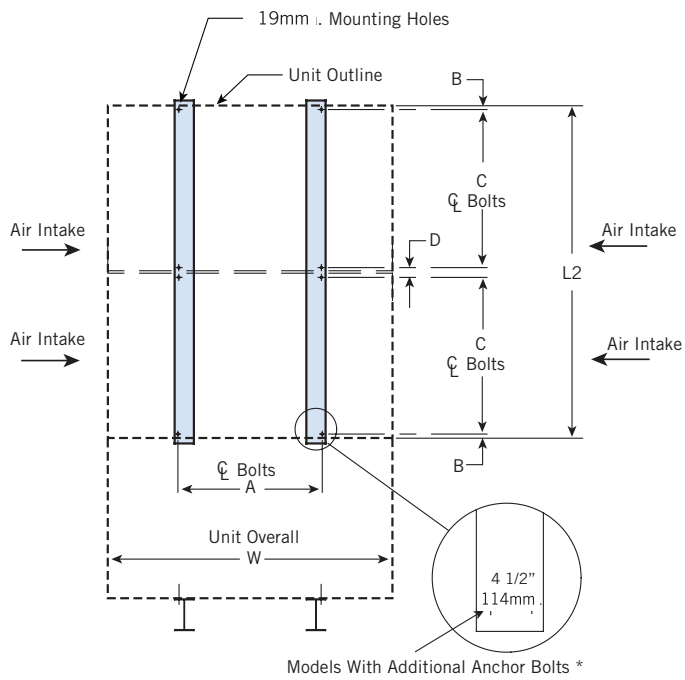

Plan C: Double Cell Unit

# Series 3000 Alternative Structural Support

The Series 3000 Cooling Towers (excluding basinless option) can accommodate Plan A (single cell) and Plan C (double cell) support with alternative spacing of anchor bolt hole center lines as listed in the table below. BAC provides specific anchorage drawings in the job file that reflect the revised anchor bolt hole center line dimension only. IBC wind and seismic load ratings are not available on alternate steel support arrangements. The unit will have pre-punched anchor bolt holes in the standard and minimum hole spacing locations only. All other alternative anchor bolt holes are located and drilled by others.

## ALTERNATIVE STRUCTURAL SUPPORT

Model Number	Standard Spacing "A" Dimension	Alternate Spacing "A" Dimension
S3E/XES3E-8518-X	2842mm	2257mm
S3E/XES3E-1020-X	3452mm	2440mm
S3E/XES3E-1222-X	3914mm	2892mm
S3E/XES3E-1424-X	4672mm	3660mm

 **NOTE:** The standard structural support figures on page 36 apply to alternative structural support as well.

## BASIN HEATERS

Evaporative cooling equipment exposed to below freezing ambient temperatures require protection to prevent freezing of the water in the cold water basin when the unit is idle. Factory-installed electric immersion heaters, which maintain 4.4°C water temperature, are a simple and inexpensive way of providing such protection.

## HEATER kW DATA

Model Number	-17.8°C Ambient Heaters		-28.9°C Ambient Heaters	
	Number of Heaters	kW per Heater	Number of Heaters	kW per Heater
S3E/XES3E-8518	2	6	2	9
S3E/XES3E-1020	2	8	2	12
S3E/XES3E-1222-06x, -07x	2	10	2	14
S3E/XES3E-1222-10x, -12x, -13x, -14x	2	12	2	15
S3E/XES3E-1424-07	2	14	2	18
S3E/XES3E-1424-12x, -13x, -14x	2	14	2	20

 **NOTE:** This table is based on 460V/3 phase/50 Hz power.



**BALTIMORE  
AIRCOIL AUSTRALIA**

## COOLING TOWERS

---

CLOSED CIRCUIT COOLING TOWERS

---

ICE THERMAL STORAGE

---

EVAPORATIVE CONDENSERS

---

HYBRID PRODUCTS

---

PARTS & SERVICES



[www.BaltimoreAircoil.com.au](http://www.BaltimoreAircoil.com.au)

120 Wisemans Ferry Road, Somersby NSW 2250 > Telephone (Australia): 1300.134.622 > Telephone (New Zealand): 0800.225.842