



RCC Evaporative Condenser

TABLE OF CONTENTS

| | | | |
|---|---------------------------|----|----------------------------|
| 2 | RCC EVAPORATIVE CONDENSER | 10 | ENGINEERING DATA |
| 4 | BENEFITS | 18 | PRODUCT LAYOUT |
| 6 | RCC CONSTRUCTION DETAILS | 22 | ENGINEERING SPECIFICATIONS |
| 8 | CUSTOM FEATURES & OPTIONS | | |

Commercial applications demand reliable, cost effective and energy efficient solutions. With an ever increasing focus on operational reliability and ease of maintenance. It is paramount that cooling equipment be also easy to inspect, clean & maintain. The RCC Evaporative Condenser responds to all these requirements thanks to built-in design features. Industrial applications face unique challenges in their processes with varying site conditions. **The RCC Evaporative Condenser provides solutions to these challenges by reducing the cost of plant design, construction, operation and ongoing maintenance, whilst improving the standard of quality & construction, required by medium to heavy industry.**



BAC's RCC: The Latest In Innovation

75 to 1,287 R-717 Tons in a Single Unit

Lowest
Refrigerant
Charge
Per Ton

Fewest
Piping
Connections

Layout
Flexibility

Shake Table
Tested to
 S_{DS} of 2.40g

Easy
Maintenance



RCC Benefits

> Compliance

- ▶ Free Draining Cold Water Basin - The sloping condenser basin allows for free draining to comply with AS3666.
- ▶ Smooth Internal Surfaces - The internal surfaces of the condenser are smooth to facilitate cleaning.
- ▶ Coil headers - Designed and type tested in accordance with AS1210 - 1997 CLASS 3 FOR HAZARD LEVEL B.

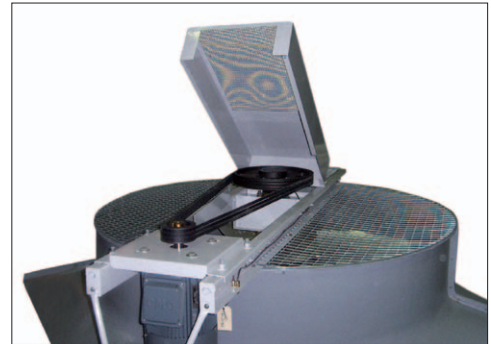

> Low Energy Consumption

- ▶ Evaporative cooling equipment minimises the energy consumption of the entire system because it provides lower operating temperatures. The owner saves money while conserving natural resources and reducing environmental impact.
- ▶ The condensers provide the heat rejection required at the lowest possible energy input via:
 - High efficiency, low kW axial fans.
 - Variable Frequency Drives.



> Low Installed Cost

Single or multiplexed configurations, common or segmented basins, partitioned or extended air inlets and increased capacity control steps, all are but a few examples of the flexible modular evaporative condenser design.

The condenser can be shipped directly from the factory as a fully assembled unit, as unit modules or knocked down, to suit diverse and often restricted on-site conditions.

The low shipping weights and modular shipping options reduce transport and crane costs. Lifting lugs, provided as standard, offer secure fixing points for safe crane lifts. Lower installation costs are achieved due to solvent welded drain connections and threaded make-up, overflow and quick-fill connections.





> Easy Maintenance

▶ ACCESS TO COMPLETE UNIT INTERIOR

The large access panels are fitted with easily removable knobs. Removing the access panels does not require any tools or dismantling of the condenser structure, providing unequalled access to all of the internal condenser components for inspection, cleaning and maintenance.

▶ BASIN ACCESSIBLE FROM ALL SIDES

Removal of the louvres, requiring no tools, provides access to all sides of the smooth faced cold water basin for inspection, cleaning and maintenance.

▶ EASY ACCESS TO FLOAT VALVE

Access to and adjustment of the float valve is simplified. The stainless steel pump suction strainer can easily be inspected, removed and cleaned inside.

▶ REMOVABLE SPRAY SYSTEM

Cleaning and inspection of the spray system can be performed insitu or by removing the spray branch arms. No tools are required for the removal of the branch arms or the individual water distribution nozzles.

▶ REMOVABLE ELIMINATORS

Removal of high efficiency drift eliminators can be accomplished easily without the removal of other internal components or by having to dismantle the condenser structure. The eliminators rest on supports specifically designed for this purpose.

▶ MOTOR OUTSIDE AIRSTREAM

Units RCC0808 and larger include an adjustable motor base plate for belt tensioning, extended lubrication lines with externally mounted grease nipples are provided as standard for ease of scheduled maintenance. Smaller units are supplied as direct drive units.

▶ EASY ACCESS TO DRIVES

Removal of the fan screen for access to belts and drives is not required. These drive components are easily accessible through the specially designed hinged belt guard for inspection adjustment or replacement purposes.



> Long Service Life

▶ SUPERIOR PULTRUDED COMPOSITE CONSTRUCTION

The use of high strength Pultruded Composite components for the primary structure combined with BAC's patented "Bonded Panel to Post Connection," offers many advantages over conventional hand laid or chopped strand fibreglass construction methods. Pultruded composites possess a superior strength to weight ratio of up to five times that of chopped strand fibreglass.

RCC Construction Details

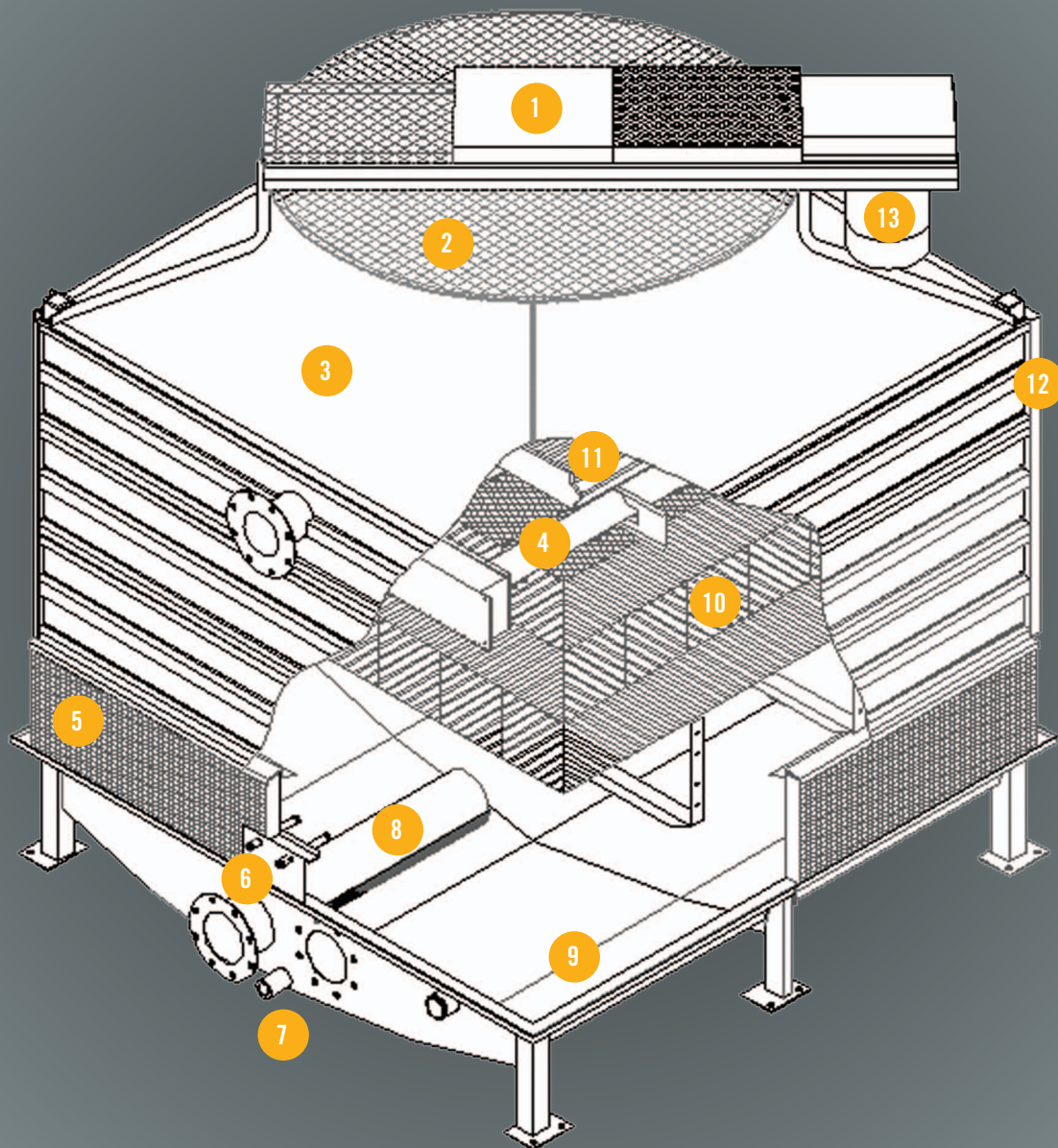

1 Drive Train

- ▶ Easy access to drives and belts for inspection and adjustment.
- ▶ Stainless steel shaft.
- ▶ Heavy-duty bearings.
- ▶ Heavy-duty SPB Belts

2 Fan

- ▶ Axial Fans.
- ▶ Small tip clearance tolerance.
- ▶ Low air inlet velocity.
- ▶ Minimum Noise.

3 Roofdeck

- ▶ Smooth faced air entry fan cylinders.
- ▶ Close manufacturing tolerances allow small tip clearance providing an increased fan efficiency.

4 Water Distribution System

- ▶ Low pressure, stationary type nozzles.
- ▶ Heavy duty PVC spray branches are grommeted to facilitate removal and cleaning.

5 Louvres

- ▶ Removal of the louvres provides access to all sides of the cold water basin for inspection, cleaning and maintenance.

6 Make-up Assembly

- ▶ Adjustable water make-up assembly, over flow and quick fill connections are supplied standard.

7 Connections

- ▶ All connections 200NB and longer are Table E Flange pattern.
- ▶ Connections 150NB and smaller are male threaded BSP.

8 Strainer

- ▶ Stainless steel construction, anti-vortex design.

9 Cold Water Basin

- ▶ The cold water basin is made of fibreglass reinforced polyester (FRP) with extra reinforcement in critical areas.
- ▶ Sloped basin sides with smooth internal finish for easy cleaning.

10 Fill

- ▶ The fill is impervious to rot, decay and resistant to fungus or biological attacks.
- ▶ Fill consists of high efficiency crossfluted sheets, assembled into lightweight blocks.
- ▶ Blocks are sized for easy handling and removal for cleaning.

11 Drift Eliminators

- ▶ UV resistant non-corrosive material, impervious to rot, decay and biological attack.
- ▶ Three distinct changes in air direction to reduce drift loss significantly.
- ▶ Assembled in easy to handle sections, which can be removed for access to the equipment interior.
- ▶ AS3666 Compliant.

12 Access Door

- ▶ The larger access door is easily removable to provide complete access to drift eliminators, spray system and fill.
- ▶ Larger units are equipped with anchor points to secure door when removed.

13 Motor

- ▶ Models RCC0505 to RCC0707 utilise direct drive motor.
- ▶ Larger units have the fan motor outside of the moist discharge air stream and use belt drives.
- ▶ Belts provide reliability and long service life with low maintenance requirements.

RCC Custom Features & Options

> Materials of Construction

▶ STANDARD CONSTRUCTION

High strength pultruded composite components for the primary structure combined with patented bonded panel to post connection.

▶ FACTORY ASSEMBLED

The RCC Condenser is completely factory-assembled.

Optional: The Condenser can be shipped in knocked-down version for assembly on site. This enables overseas transport in containers and significantly reduces transport cost.

▶ LADDER AND PLATFORM

For the purposes of access to the drive system for inspection or maintenance, ladders and platforms can be provided. These can either take the form of factory assembled pods for inspection, or customised ladders and platforms designed to meet site specific conditions. All ladders and platforms are designed in accordance with AS1657. Ladders can be supplied at any length within the constraints of the standard.



> Drive System

▶ DIRECT DRIVE

High efficiency fans with direct drive motors for models RCC0505 to RCC0707. Larger models are belt driven. All belt driven units have extended lubrication lines to the edge of the fan cylinder. The mechanical equipment support is made of ZAM coated steel. Fan guards are made of hot dip galvanised steel.

Optional: Mechanical equipment support assembly and fan guards in SST 304 or SST 316.

▶ VIBRATION CUT-OUT SWITCH

A factory-mounted vibration cut-out switch is available to effectively protect against equipment failure due to excessive vibration of the mechanical equipment system. BAC can provide a vibration cut-out switch in an IP65 enclosure to ensure reliable protection.





▶ CONTROLS

BAC provide optional preprogrammed VFD's using the design conditions provided with the evaporative cooling equipment and the fan motor data at time of manufacture. These factory settings provide the evaporative equipment operator or commissioning personnel the flexibility to start the equipment using the factory preprogrammed settings or customise any of the control parameters to suit the application or site specific conditions. The VFD is programmed in PID Control with Auto Start, Sleep Mode and a Set Point Reference. A Pressure Sensor is factory installed at the condenser coil outlet which measures the leaving refrigerant pressure.

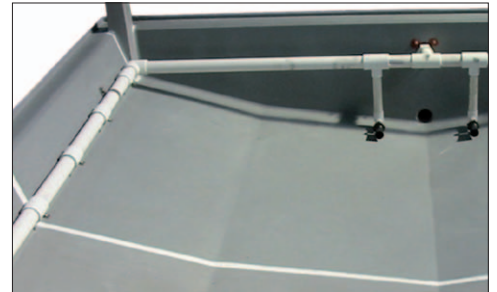

> Cold Water Basin

The RCC Condenser cold water basin is constructed of high performance fibreglass reinforced polyester and includes make-up, quick-fill, overflow, and drain connection.

Optional: Units can be supplied without cold water basin for field assembly on a concrete tank.



▶ BASIN SWEEPER PIPING

Basin sweeper piping provides an effective method of preventing sediment from collecting in the cold water basin of the unit. A complete piping system, including nozzles, is provided in the unit basin for connection to side stream filtration equipment.



> Heat Transfer Surface Alternatives

Prime surface heat transfer coils are available in either hot-dip galvanised steel or stainless steel. Both options are designed in accordance with AS2971 and manufactured within an ISO:9001 certified Quality Assurance Program. Each coil is pressure tested to 2750 kPa after fabrication and prior to final assembly of the RCC Evaporative Condenser.



RCC Engineering Data

Engineering Data - 304SST Coil Unit Dimensions

| Model No. RCC (SST Coil) | W (mm) | L (mm) | H (mm) | A | B | Shipping Weight (kg) | Operating Weight (kg) | Heaviest Section (kg) | Fan Motor (kW) | Air Flow (m ³ /s) | Water Flow (l/s) | Pump Motor (kW) | Drain NB (mm) | Overflow NB (mm) | Make -Up NB (mm) | Quick -fill NB (mm) |
|--------------------------------|-----------|-----------|-----------|------|------|----------------------------|-----------------------------|-----------------------------|----------------------|------------------------------------|------------------------|-----------------------|---------------------|------------------------|---------------------------|------------------------------|
| RCC0505-2-I | 1675 | 1675 | 3315 | 910 | 1120 | 1380 | 2300 | 1050 | 4 | 7.61 | 6.8 | 0.55 | 50 | 50 | 15 | 15 |
| RCC0505-3-I | 1675 | 1675 | 3510 | 910 | 1315 | 1560 | 2550 | 1230 | 4 | 7.28 | 6.8 | 0.55 | 50 | 50 | 15 | 15 |
| RCC0505-3-J | 1675 | 1675 | 3510 | 910 | 1315 | 1560 | 2550 | 1230 | 5.5 | 8.31 | 6.8 | 0.55 | 50 | 50 | 15 | 15 |
| RCC0606-2-G | 1980 | 1980 | 3585 | 970 | 1120 | 1830 | 3150 | 1549 | 2.2 | 8.15 | 9.8 | 1.1 | 50 | 50 | 15 | 15 |
| RCC0606-2-I | 1980 | 1980 | 3585 | 970 | 1120 | 1830 | 3150 | 1549 | 4 | 9.69 | 9.8 | 1.1 | 50 | 50 | 15 | 15 |
| RCC0606-2-J | 1980 | 1980 | 3585 | 970 | 1120 | 1830 | 3150 | 1549 | 5.5 | 11.06 | 9.8 | 1.1 | 50 | 50 | 15 | 15 |
| RCC0606-3-I | 1980 | 1980 | 3780 | 970 | 1315 | 2080 | 3500 | 1800 | 4 | 9.28 | 9.8 | 1.1 | 50 | 50 | 15 | 15 |
| RCC0606-3-J | 1980 | 1980 | 3780 | 970 | 1315 | 2080 | 3500 | 1800 | 5.5 | 10.59 | 9.8 | 1.1 | 50 | 50 | 15 | 15 |
| RCC0606-3-K | 1980 | 1980 | 3780 | 970 | 1315 | 2080 | 3500 | 1800 | 7.5 | 11.75 | 9.8 | 1.1 | 50 | 50 | 15 | 15 |
| RCC0707-2-I | 2285 | 2285 | 3775 | 1025 | 1120 | 2390 | 4100 | 2050 | 4 | 11.91 | 13.3 | 1.1 | 50 | 50 | 20 | 20 |
| RCC0707-2-J | 2285 | 2285 | 3775 | 1025 | 1120 | 2390 | 4100 | 2050 | 5.5 | 13.59 | 13.3 | 1.1 | 50 | 50 | 20 | 20 |
| RCC0707-2-K | 2285 | 2285 | 3775 | 1025 | 1120 | 2390 | 4100 | 2050 | 7.5 | 15.07 | 13.3 | 1.1 | 50 | 50 | 20 | 20 |
| RCC0707-3-J | 2285 | 2285 | 3970 | 1025 | 1315 | 2730 | 4600 | 2390 | 5.5 | 13.01 | 13.3 | 1.1 | 50 | 50 | 20 | 20 |
| RCC0707-3-K | 2285 | 2285 | 3970 | 1025 | 1315 | 2730 | 4600 | 2390 | 7.5 | 14.43 | 13.3 | 1.1 | 50 | 50 | 20 | 20 |
| RCC0707-3-L | 2285 | 2285 | 3970 | 1025 | 1315 | 2730 | 4600 | 2390 | 11 | 16.40 | 13.3 | 1.1 | 50 | 50 | 20 | 20 |
| RCC0808-2-K | 2590 | 2590 | 3755 | 1075 | 1120 | 3050 | 5250 | 2790 | 7.5 | 18.01 | 17.4 | 1.5 | 50 | 80 | 20 | 20 |
| RCC0808-2-L | 2590 | 2590 | 3755 | 1075 | 1120 | 3050 | 5250 | 2790 | 11 | 20.46 | 17.4 | 1.5 | 50 | 80 | 20 | 20 |
| RCC0808-3-K | 2590 | 2590 | 3950 | 1075 | 1315 | 3500 | 5850 | 3230 | 7.5 | 17.24 | 17.4 | 1.5 | 50 | 80 | 20 | 20 |
| RCC0808-3-L | 2590 | 2590 | 3950 | 1075 | 1315 | 3500 | 5850 | 3230 | 11 | 19.59 | 17.4 | 1.5 | 50 | 80 | 20 | 20 |
| RCC0909-2-K | 2895 | 2895 | 3885 | 1135 | 1120 | 3810 | 6450 | 3500 | 7.5 | 21.07 | 22.0 | 1.5 | 50 | 80 | 20 | 20 |
| RCC0909-2-L | 2895 | 2895 | 3885 | 1135 | 1120 | 3810 | 6450 | 3500 | 11 | 23.94 | 22.0 | 1.5 | 50 | 80 | 20 | 20 |
| RCC0909-3-L | 2895 | 2895 | 4080 | 1135 | 1315 | 4380 | 7200 | 4060 | 11 | 22.92 | 22.0 | 1.5 | 50 | 80 | 20 | 20 |
| RCC0909-3-M | 2895 | 2895 | 4080 | 1135 | 1315 | 4380 | 7200 | 4060 | 15 | 25.41 | 22.0 | 1.5 | 50 | 80 | 20 | 20 |
| RCC1010-2-L | 3200 | 3200 | 4125 | 1190 | 1120 | 4580 | 7750 | 4210 | 11 | 27.55 | 27.1 | 2.2 | 50 | 80 | 40 | 40 |
| RCC1010-2-M | 3200 | 3200 | 4125 | 1190 | 1120 | 4580 | 7750 | 4210 | 15 | 30.55 | 27.1 | 2.2 | 50 | 80 | 40 | 40 |
| RCC1010-3-L | 3200 | 3200 | 4320 | 1190 | 1315 | 5280 | 8700 | 4910 | 11 | 26.38 | 27.1 | 2.2 | 50 | 80 | 40 | 40 |
| RCC1010-3-M | 3200 | 3200 | 4320 | 1190 | 1315 | 5280 | 8700 | 4910 | 15 | 29.25 | 27.1 | 2.2 | 50 | 80 | 40 | 40 |
| RCC1010-3-N | 3200 | 3200 | 4320 | 1190 | 1315 | 5280 | 8700 | 4910 | 18.5 | 31.37 | 27.1 | 2.2 | 50 | 80 | 40 | 40 |
| RCC1111-2-M | 3500 | 3500 | 4290 | 1355 | 1120 | 5450 | 9150 | 5040 | 15 | 34.69 | 32.8 | 3 | 50 | 80 | 40 | 40 |
| RCC1111-2-N | 3500 | 3500 | 4290 | 1355 | 1120 | 5450 | 9150 | 5040 | 18.5 | 37.20 | 32.8 | 3 | 50 | 80 | 40 | 40 |
| RCC1111-3-M | 3500 | 3500 | 4485 | 1355 | 1315 | 6300 | 10300 | 5880 | 15 | 33.21 | 32.8 | 3 | 50 | 80 | 40 | 40 |
| RCC1111-3-N | 3500 | 3500 | 4485 | 1355 | 1315 | 6300 | 10300 | 5880 | 18.5 | 35.62 | 32.8 | 3 | 50 | 80 | 40 | 40 |
| RCC1111-3-O | 3500 | 3500 | 4485 | 1355 | 1315 | 6300 | 10300 | 5880 | 22 | 37.74 | 32.8 | 3 | 50 | 80 | 40 | 40 |



> Engineering Data - 304SST Coil Unit Dimensions

Single Fan Units - Square Box Sizes

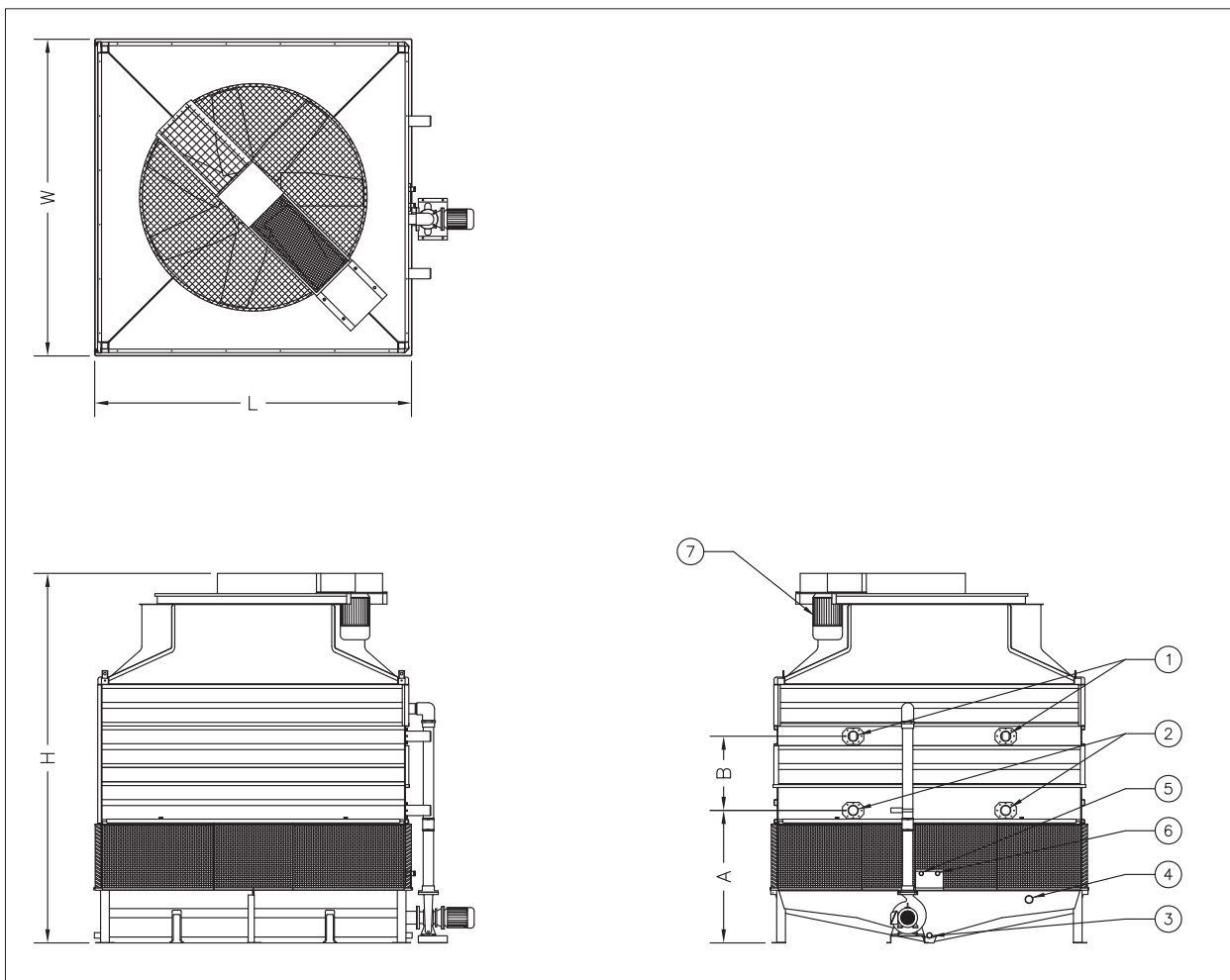

1. Refrigerant Inlet 100NB (Box Size 5x5, 6x6, 7x7 and 7x10.5 Have Single Coil Connection); 2. Refrigerant Outlet 100NB (Box Size 5x5, 6x6, 7x7 and 7x10.5 Have Single Coil Connection); 3. Drain; 4. Overflow; 5. Make-Up; 6. Quick Fill; 7. Fan Motor.

RCC Engineering Data

> Engineering Data - 304SST Coil Unit Dimensions

| Model No. RCC (SST Coil) | W (mm) | L (mm) | H (mm) | A | B | Shipping Weight (kg) | Operating Weight (kg) | Heaviest Section (kg) | Fan Motor (kW) | Air Flow (m ³ /s) | Water Flow (l/s) | Pump Motor (kW) | Drain NB (mm) | Overflow NB (mm) | Make -Up NB (mm) | Quick -fill NB (mm) |
|--------------------------------|-----------|-----------|-----------|------|------|----------------------------|-----------------------------|-----------------------------|----------------------|------------------------------------|------------------------|-----------------------|---------------------|------------------------|---------------------------|------------------------------|
| RCC0710-2-J | 2285 | 3270 | 4535 | 1310 | 1120 | 3580 | 6150 | 3070 | 5.5 | 15.92 | 20.4 | 1.5 | 50 | 80 | 40 | 40 |
| RCC0710-2-K | 2285 | 3270 | 4535 | 1310 | 1120 | 3580 | 6150 | 3070 | 7.5 | 17.65 | 20.4 | 1.5 | 50 | 80 | 40 | 40 |
| RCC0710-2-L | 2285 | 3270 | 4535 | 1310 | 1120 | 3580 | 6150 | 3070 | 11 | 20.06 | 20.4 | 1.5 | 50 | 80 | 40 | 40 |
| RCC0710-3-L | 2285 | 3270 | 4710 | 1310 | 1315 | 4090 | 6850 | 3580 | 11 | 19.21 | 20.4 | 1.5 | 50 | 80 | 40 | 40 |
| RCC0710-3-M | 2285 | 3270 | 4710 | 1310 | 1315 | 4090 | 6850 | 3580 | 15 | 21.30 | 20.4 | 1.5 | 50 | 80 | 40 | 40 |
| RCC0812-2-L | 2590 | 3880 | 4465 | 1310 | 1120 | 4560 | 7850 | 4180 | 11 | 23.99 | 26.5 | 2.2 | 50 | 80 | 40 | 40 |
| RCC0812-2-M | 2590 | 3880 | 4465 | 1310 | 1120 | 4560 | 7850 | 4180 | 15 | 26.60 | 26.5 | 2.2 | 50 | 80 | 40 | 40 |
| RCC0812-3-L | 2590 | 3880 | 4640 | 1310 | 1315 | 5230 | 8750 | 4850 | 11 | 22.97 | 26.5 | 2.2 | 50 | 80 | 40 | 40 |
| RCC0812-3-M | 2590 | 3880 | 4640 | 1310 | 1315 | 5230 | 8750 | 4850 | 15 | 25.47 | 26.5 | 2.2 | 50 | 80 | 40 | 40 |
| RCC0812-3-N | 2590 | 3880 | 4640 | 1310 | 1315 | 5230 | 8750 | 4850 | 18.5 | 27.31 | 26.5 | 2.2 | 50 | 80 | 40 | 40 |
| RCC0913-2-M | 2895 | 4335 | 4525 | 1300 | 1120 | 5710 | 9650 | 5250 | 15 | 31.14 | 33.5 | 3 | 50 | 80 | 40 | 40 |
| RCC0913-2-N | 2895 | 4335 | 4525 | 1300 | 1120 | 5710 | 9650 | 5250 | 18.5 | 33.40 | 33.5 | 3 | 50 | 80 | 40 | 40 |
| RCC0913-3-M | 2895 | 4335 | 4700 | 1300 | 1315 | 6560 | 10800 | 6090 | 15 | 29.82 | 33.5 | 3 | 50 | 80 | 40 | 40 |
| RCC0913-3-N | 2895 | 4335 | 4700 | 1300 | 1315 | 6560 | 10800 | 6090 | 18.5 | 31.98 | 33.5 | 3 | 50 | 80 | 40 | 40 |
| RCC0913-3-O | 2895 | 4335 | 4700 | 1300 | 1315 | 6560 | 10800 | 6090 | 22 | 33.88 | 33.5 | 3 | 50 | 80 | 40 | 40 |
| RCC1015-2-N | 3200 | 4790 | 4720 | 1310 | 1120 | 6870 | 11600 | 6310 | 18.5 | 38.46 | 41.3 | 4 | 50 | 80 | 40 | 40 |
| RCC1015-2-O | 3200 | 4790 | 4720 | 1310 | 1120 | 6870 | 11600 | 6310 | 22 | 40.74 | 41.3 | 4 | 50 | 80 | 40 | 40 |
| RCC1015-3-N | 3200 | 4790 | 4895 | 1310 | 1315 | 7920 | 13000 | 7360 | 18.5 | 36.82 | 41.3 | 4 | 50 | 80 | 40 | 40 |
| RCC1015-3-O | 3200 | 4790 | 4895 | 1310 | 1315 | 7920 | 13000 | 7360 | 22 | 39.01 | 41.3 | 4 | 50 | 80 | 40 | 40 |
| RCC1015-3-P | 3200 | 4790 | 4895 | 1310 | 1315 | 7920 | 13000 | 7360 | 30 | 43.26 | 41.3 | 4 | 50 | 80 | 40 | 40 |
| RCC1116-2-O | 3500 | 5247 | 4905 | 1510 | 1120 | 8180 | 13700 | 7560 | 22 | 46.28 | 49.9 | 5.5 | 50 | 80 | 40 | 40 |
| RCC1116-2-P | 3500 | 5247 | 4905 | 1510 | 1120 | 8180 | 13700 | 7560 | 30 | 51.32 | 49.9 | 5.5 | 50 | 80 | 40 | 40 |
| RCC1116-3-O | 3500 | 5247 | 5080 | 1510 | 1315 | 9450 | 15400 | 8820 | 22 | 44.32 | 49.9 | 5.5 | 50 | 80 | 40 | 40 |
| RCC1116-3-P | 3500 | 5247 | 5080 | 1510 | 1315 | 9450 | 15400 | 8820 | 30 | 49.14 | 49.9 | 5.5 | 50 | 80 | 40 | 40 |



> Engineering Data - 304SST Coil Unit Dimensions

Single Fan Units - Rectangular Box Sizes

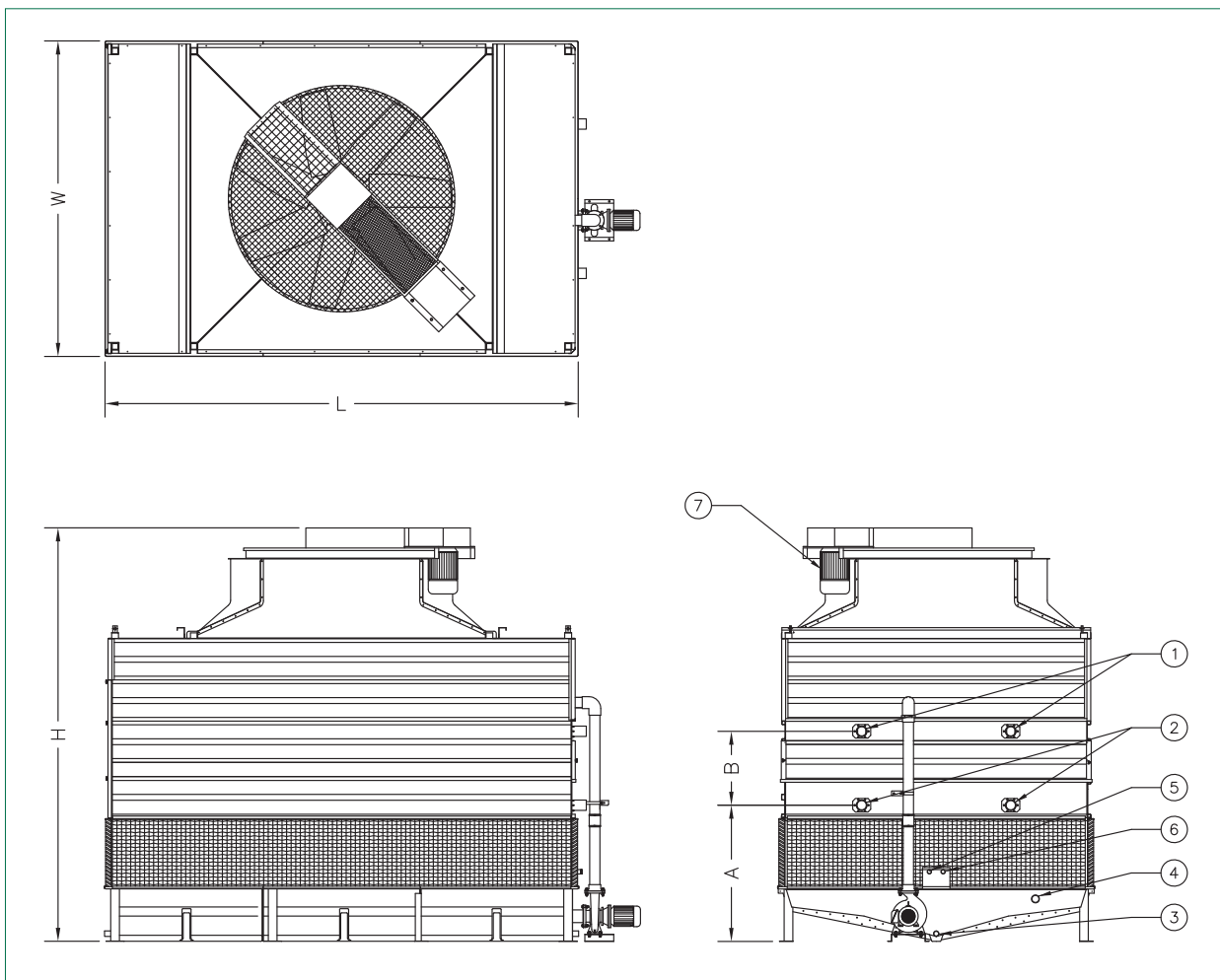

1. Refrigerant Inlet 100NB (Box Size 5x5, 6x6, 7x7 and 7x10.5 Have Single Coil Connection); 2. Refrigerant Outlet 100NB (Box Size 5x5, 6x6, 7x7 and 7x10.5 Have Single Coil Connection); 3. Drain; 4. Overflow; 5. Make-Up; 6. Quick Fill; 7. Fan Motor.

RCC Engineering Data

> Engineering Data - HDG Coil Unit Dimensions

| Model No. RCC (SST Coil) | W (mm) | L (mm) | H (mm) | A | B | Shipping Weight (kg) | Operating Weight (kg) | Heaviest Section (kg) | Fan Motor (kW) | Air Flow (m³/s) | Water Flow (l/s) | Pump Motor (kW) | Drain NB (mm) | Overflow NB (mm) | Make -Up NB (mm) | Quick -fill NB (mm) |
|--------------------------------|-----------|-----------|-----------|------|------|----------------------------|-----------------------------|-----------------------------|----------------------|-----------------------|------------------------|-----------------------|---------------------|------------------------|---------------------------|------------------------------|
| RCC0505-2-I | 1675 | 1675 | 3010 | 910 | 820 | 1380 | 2300 | 1050 | 4 | 7.61 | 6.8 | 0.55 | 50 | 50 | 15 | 15 |
| RCC0505-3-I | 1675 | 1675 | 3315 | 910 | 1120 | 1560 | 2550 | 1230 | 4 | 7.28 | 6.8 | 0.55 | 50 | 50 | 15 | 15 |
| RCC0505-3-J | 1675 | 1675 | 3315 | 910 | 1120 | 1560 | 2550 | 1230 | 5.5 | 8.31 | 6.8 | 0.55 | 50 | 50 | 15 | 15 |
| RCC0606-2-G | 1980 | 1980 | 3280 | 970 | 820 | 1830 | 3150 | 1549 | 2.2 | 8.15 | 9.8 | 1.1 | 50 | 50 | 15 | 15 |
| RCC0606-2-I | 1980 | 1980 | 3280 | 970 | 820 | 1830 | 3150 | 1549 | 4 | 9.69 | 9.8 | 1.1 | 50 | 50 | 15 | 15 |
| RCC0606-2-J | 1980 | 1980 | 3280 | 970 | 820 | 1830 | 3150 | 1549 | 5.5 | 11.06 | 9.8 | 1.1 | 50 | 50 | 15 | 15 |
| RCC0606-3-I | 1980 | 1980 | 3585 | 970 | 1120 | 2080 | 3500 | 1800 | 4 | 9.28 | 9.8 | 1.1 | 50 | 50 | 15 | 15 |
| RCC0606-3-J | 1980 | 1980 | 3585 | 970 | 1120 | 2080 | 3500 | 1800 | 5.5 | 10.59 | 9.8 | 1.1 | 50 | 50 | 15 | 15 |
| RCC0606-3-K | 1980 | 1980 | 3585 | 970 | 1120 | 2080 | 3500 | 1800 | 7.5 | 11.75 | 9.8 | 1.1 | 50 | 50 | 15 | 15 |
| RCC0707-2-I | 2285 | 2285 | 3470 | 1025 | 820 | 2390 | 4100 | 2050 | 4 | 11.91 | 13.3 | 1.1 | 50 | 50 | 20 | 20 |
| RCC0707-2-J | 2285 | 2285 | 3470 | 1025 | 820 | 2390 | 4100 | 2050 | 5.5 | 13.59 | 13.3 | 1.1 | 50 | 50 | 20 | 20 |
| RCC0707-2-K | 2285 | 2285 | 3470 | 1025 | 820 | 2390 | 4100 | 2050 | 7.5 | 15.07 | 13.3 | 1.1 | 50 | 50 | 20 | 20 |
| RCC0707-3-J | 2285 | 2285 | 3775 | 1025 | 1120 | 2730 | 4600 | 2390 | 5.5 | 13.01 | 13.3 | 1.1 | 50 | 50 | 20 | 20 |
| RCC0707-3-K | 2285 | 2285 | 3775 | 1025 | 1120 | 2730 | 4600 | 2390 | 7.5 | 14.43 | 13.3 | 1.1 | 50 | 50 | 20 | 20 |
| RCC0707-3-L | 2285 | 2285 | 3775 | 1025 | 1120 | 2730 | 4600 | 2390 | 11 | 16.40 | 13.3 | 1.1 | 50 | 50 | 20 | 20 |
| RCC0808-2-K | 2590 | 2590 | 3450 | 1075 | 820 | 3050 | 5250 | 2790 | 7.5 | 18.01 | 17.4 | 1.5 | 50 | 80 | 20 | 20 |
| RCC0808-2-L | 2590 | 2590 | 3450 | 1075 | 820 | 3050 | 5250 | 2790 | 11 | 20.46 | 17.4 | 1.5 | 50 | 80 | 20 | 20 |
| RCC0808-3-K | 2590 | 2590 | 3755 | 1075 | 1120 | 3500 | 5850 | 3230 | 7.5 | 17.24 | 17.4 | 1.5 | 50 | 80 | 20 | 20 |
| RCC0808-3-L | 2590 | 2590 | 3755 | 1075 | 1120 | 3500 | 5850 | 3230 | 11 | 19.59 | 17.4 | 1.5 | 50 | 80 | 20 | 20 |
| RCC0909-2-K | 2895 | 2895 | 3580 | 1135 | 820 | 3810 | 6450 | 3500 | 7.5 | 21.07 | 22.0 | 1.5 | 50 | 80 | 20 | 20 |
| RCC0909-2-L | 2895 | 2895 | 3580 | 1135 | 820 | 3810 | 6450 | 3500 | 11 | 23.94 | 22.0 | 1.5 | 50 | 80 | 20 | 20 |
| RCC0909-3-L | 2895 | 2895 | 3885 | 1135 | 1120 | 4380 | 7200 | 4060 | 11 | 22.92 | 22.0 | 1.5 | 50 | 80 | 20 | 20 |
| RCC0909-3-M | 2895 | 2895 | 3885 | 1135 | 1120 | 4380 | 7200 | 4060 | 15 | 25.41 | 22.0 | 1.5 | 50 | 80 | 20 | 20 |
| RCC1010-2-L | 3200 | 3200 | 3820 | 1190 | 820 | 4580 | 7750 | 4210 | 11 | 27.55 | 27.1 | 2.2 | 50 | 80 | 40 | 40 |
| RCC1010-2-M | 3200 | 3200 | 3820 | 1190 | 820 | 4580 | 7750 | 4210 | 15 | 30.55 | 27.1 | 2.2 | 50 | 80 | 40 | 40 |
| RCC1010-3-L | 3200 | 3200 | 4125 | 1190 | 1120 | 5280 | 8700 | 4910 | 11 | 26.38 | 27.1 | 2.2 | 50 | 80 | 40 | 40 |
| RCC1010-3-M | 3200 | 3200 | 4125 | 1190 | 1120 | 5280 | 8700 | 4910 | 15 | 29.25 | 27.1 | 2.2 | 50 | 80 | 40 | 40 |
| RCC1010-3-N | 3200 | 3200 | 4125 | 1190 | 1120 | 5280 | 8700 | 4910 | 18.5 | 31.37 | 27.1 | 2.2 | 50 | 80 | 40 | 40 |
| RCC1111-2-M | 3500 | 3500 | 3985 | 1355 | 820 | 5450 | 9150 | 5040 | 15 | 34.69 | 32.8 | 3 | 50 | 80 | 40 | 40 |
| RCC1111-2-N | 3500 | 3500 | 3985 | 1355 | 820 | 5450 | 9150 | 5040 | 18.5 | 37.20 | 32.8 | 3 | 50 | 80 | 40 | 40 |
| RCC1111-3-M | 3500 | 3500 | 4290 | 1355 | 1120 | 6300 | 10300 | 5880 | 15 | 33.21 | 32.8 | 3 | 50 | 80 | 40 | 40 |
| RCC1111-3-N | 3500 | 3500 | 4290 | 1355 | 1120 | 6300 | 10300 | 5880 | 18.5 | 35.62 | 32.8 | 3 | 50 | 80 | 40 | 40 |
| RCC1111-3-O | 3500 | 3500 | 4290 | 1355 | 1120 | 6300 | 10300 | 5880 | 22 | 37.74 | 32.8 | 3 | 50 | 80 | 40 | 40 |



Engineering Data - HDG Coil Unit Dimensions

Single Fan Units - Rectangular Box Sizes

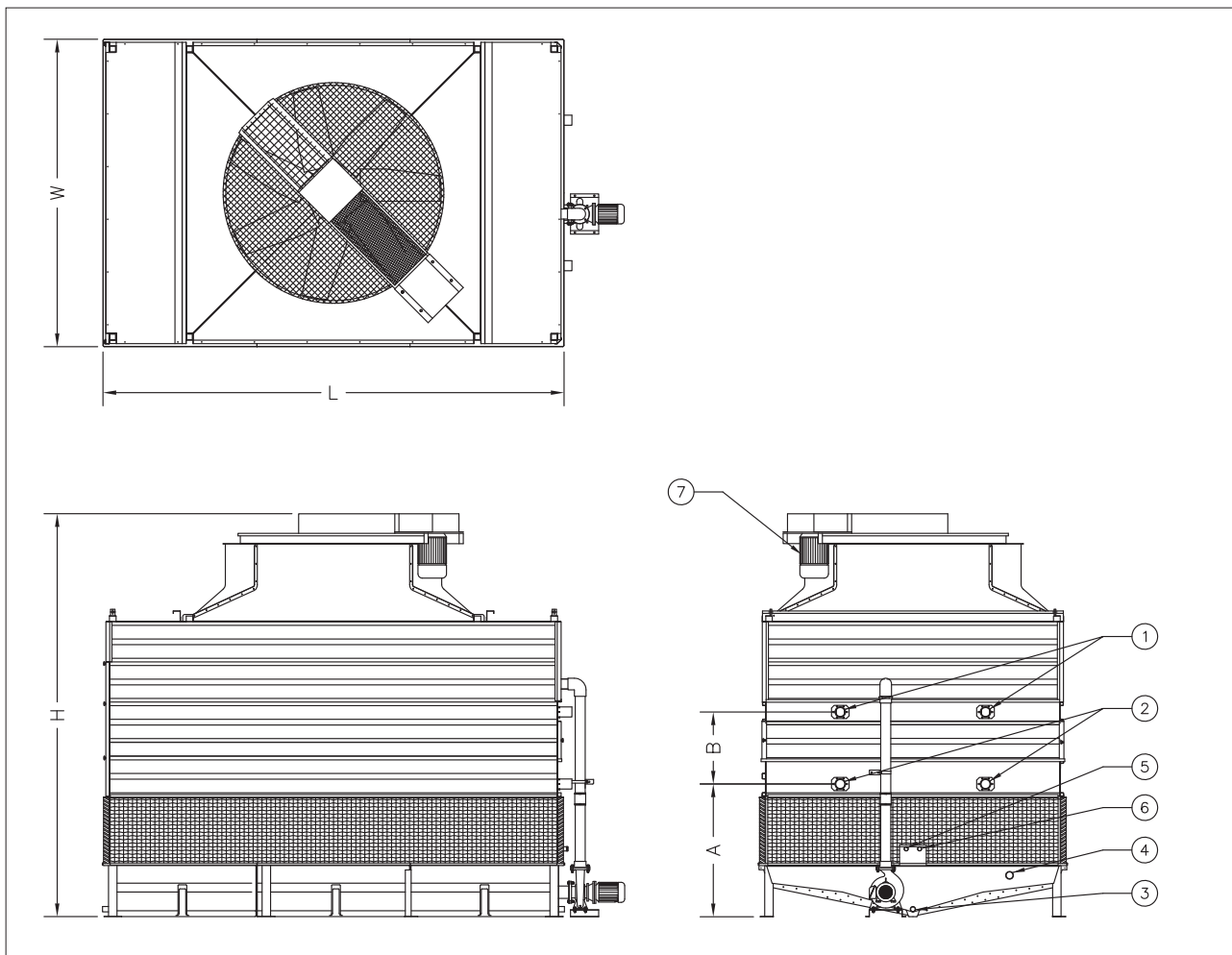

1. Refrigerant Inlet 100NB (Box Size 5x5, 6x6, 7x7 and 7x10.5 Have Single Coil Connection); 2. Refrigerant Outlet 100NB (Box Size 5x5, 6x6, 7x7 and 7x10.5 Have Single Coil Connection); 3. Drain; 4. Overflow; 5. Make-Up; 6. Quick Fill; 7. Fan Motor.

RCC Engineering Data

Engineering Data - HDG Coil Unit Dimensions

| Model No. RCF (SST Coil) | W (mm) | L (mm) | H (mm) | A | B | Shipping Weight (kg) | Operating Weight (kg) | Heaviest Section (kg) | Fan Motor (kW) | Air Flow (m³/s) | Water Flow (l/s) | Pump Motor (kW) | Drain NB (mm) | Overflow NB (mm) | Make -Up NB (mm) | Quick -fill NB (mm) |
|--------------------------------|-----------|-----------|-----------|------|------|----------------------------|-----------------------------|-----------------------------|----------------------|-----------------------|------------------------|-----------------------|---------------------|------------------------|---------------------------|------------------------------|
| RCF0505-2-I | 1675 | 1675 | 3010 | 910 | 820 | 1380 | 2300 | 1050 | 4 | 7.61 | 6.8 | 0.55 | 50 | 50 | 15 | 15 |
| RCF0505-3-I | 1675 | 1675 | 3315 | 910 | 1120 | 1560 | 2550 | 1230 | 4 | 7.28 | 6.8 | 0.55 | 50 | 50 | 15 | 15 |
| RCF0505-3-J | 1675 | 1675 | 3315 | 910 | 1120 | 1560 | 2550 | 1230 | 5.5 | 8.31 | 6.8 | 0.55 | 50 | 50 | 15 | 15 |
| RCF0606-2-G | 1980 | 1980 | 3280 | 970 | 820 | 1830 | 3150 | 1549 | 2.2 | 8.15 | 9.8 | 1.1 | 50 | 50 | 15 | 15 |
| RCF0606-2-I | 1980 | 1980 | 3280 | 970 | 820 | 1830 | 3150 | 1549 | 4 | 9.69 | 9.8 | 1.1 | 50 | 50 | 15 | 15 |
| RCF0606-2-J | 1980 | 1980 | 3280 | 970 | 820 | 1830 | 3150 | 1549 | 5.5 | 11.06 | 9.8 | 1.1 | 50 | 50 | 15 | 15 |
| RCF0606-3-I | 1980 | 1980 | 3585 | 970 | 1120 | 2080 | 3500 | 1800 | 4 | 9.28 | 9.8 | 1.1 | 50 | 50 | 15 | 15 |
| RCF0606-3-J | 1980 | 1980 | 3585 | 970 | 1120 | 2080 | 3500 | 1800 | 5.5 | 10.59 | 9.8 | 1.1 | 50 | 50 | 15 | 15 |
| RCF0606-3-K | 1980 | 1980 | 3585 | 970 | 1120 | 2080 | 3500 | 1800 | 7.5 | 11.75 | 9.8 | 1.1 | 50 | 50 | 15 | 15 |
| RCF0707-2-I | 2285 | 2285 | 3470 | 1025 | 820 | 2390 | 4100 | 2050 | 4 | 11.91 | 13.3 | 1.1 | 50 | 50 | 20 | 20 |
| RCF0707-2-J | 2285 | 2285 | 3470 | 1025 | 820 | 2390 | 4100 | 2050 | 5.5 | 13.59 | 13.3 | 1.1 | 50 | 50 | 20 | 20 |
| RCF0707-2-K | 2285 | 2285 | 3470 | 1025 | 820 | 2390 | 4100 | 2050 | 7.5 | 15.07 | 13.3 | 1.1 | 50 | 50 | 20 | 20 |
| RCF0707-3-J | 2285 | 2285 | 3775 | 1025 | 1120 | 2730 | 4600 | 2390 | 5.5 | 13.01 | 13.3 | 1.1 | 50 | 50 | 20 | 20 |
| RCF0707-3-K | 2285 | 2285 | 3775 | 1025 | 1120 | 2730 | 4600 | 2390 | 7.5 | 14.43 | 13.3 | 1.1 | 50 | 50 | 20 | 20 |
| RCF0707-3-L | 2285 | 2285 | 3775 | 1025 | 1120 | 2730 | 4600 | 2390 | 11 | 16.40 | 13.3 | 1.1 | 50 | 50 | 20 | 20 |
| RCF0808-2-K | 2590 | 2590 | 3450 | 1075 | 820 | 3050 | 5250 | 2790 | 7.5 | 18.01 | 17.4 | 1.5 | 50 | 80 | 20 | 20 |
| RCF0808-2-L | 2590 | 2590 | 3450 | 1075 | 820 | 3050 | 5250 | 2790 | 11 | 20.46 | 17.4 | 1.5 | 50 | 80 | 20 | 20 |
| RCF0808-3-K | 2590 | 2590 | 3755 | 1075 | 1120 | 3500 | 5850 | 3230 | 7.5 | 17.24 | 17.4 | 1.5 | 50 | 80 | 20 | 20 |
| RCF0808-3-L | 2590 | 2590 | 3755 | 1075 | 1120 | 3500 | 5850 | 3230 | 11 | 19.59 | 17.4 | 1.5 | 50 | 80 | 20 | 20 |
| RCF0909-2-K | 2895 | 2895 | 3580 | 1135 | 820 | 3810 | 6450 | 3500 | 7.5 | 21.07 | 22.0 | 1.5 | 50 | 80 | 20 | 20 |
| RCF0909-2-L | 2895 | 2895 | 3580 | 1135 | 820 | 3810 | 6450 | 3500 | 11 | 23.94 | 22.0 | 1.5 | 50 | 80 | 20 | 20 |
| RCF0909-3-L | 2895 | 2895 | 3885 | 1135 | 1120 | 4380 | 7200 | 4060 | 11 | 22.92 | 22.0 | 1.5 | 50 | 80 | 20 | 20 |
| RCF0909-3-M | 2895 | 2895 | 3885 | 1135 | 1120 | 4380 | 7200 | 4060 | 15 | 25.41 | 22.0 | 1.5 | 50 | 80 | 20 | 20 |
| RCF1010-2-L | 3200 | 3200 | 3820 | 1190 | 820 | 4580 | 7750 | 4210 | 11 | 27.55 | 27.1 | 2.2 | 50 | 80 | 40 | 40 |
| RCF1010-2-M | 3200 | 3200 | 3820 | 1190 | 820 | 4580 | 7750 | 4210 | 15 | 30.55 | 27.1 | 2.2 | 50 | 80 | 40 | 40 |
| RCF1010-3-L | 3200 | 3200 | 4125 | 1190 | 1120 | 5280 | 8700 | 4910 | 11 | 26.38 | 27.1 | 2.2 | 50 | 80 | 40 | 40 |
| RCF1010-3-M | 3200 | 3200 | 4125 | 1190 | 1120 | 5280 | 8700 | 4910 | 15 | 29.25 | 27.1 | 2.2 | 50 | 80 | 40 | 40 |
| RCF1010-3-N | 3200 | 3200 | 4125 | 1190 | 1120 | 5280 | 8700 | 4910 | 18.5 | 31.37 | 27.1 | 2.2 | 50 | 80 | 40 | 40 |
| RCF1111-2-M | 3500 | 3500 | 3985 | 1355 | 820 | 5450 | 9150 | 5040 | 15 | 34.69 | 32.8 | 3 | 50 | 80 | 40 | 40 |
| RCF1111-2-N | 3500 | 3500 | 3985 | 1355 | 820 | 5450 | 9150 | 5040 | 18.5 | 37.20 | 32.8 | 3 | 50 | 80 | 40 | 40 |
| RCF1111-3-M | 3500 | 3500 | 4290 | 1355 | 1120 | 6300 | 10300 | 5880 | 15 | 33.21 | 32.8 | 3 | 50 | 80 | 40 | 40 |
| RCF1111-3-N | 3500 | 3500 | 4290 | 1355 | 1120 | 6300 | 10300 | 5880 | 18.5 | 35.62 | 32.8 | 3 | 50 | 80 | 40 | 40 |
| RCF1111-3-O | 3500 | 3500 | 4290 | 1355 | 1120 | 6300 | 10300 | 5880 | 22 | 37.74 | 32.8 | 3 | 50 | 80 | 40 | 40 |



> Engineering Data - HDG Coil Unit Dimensions

Single Fan Units - Square Box Sizes

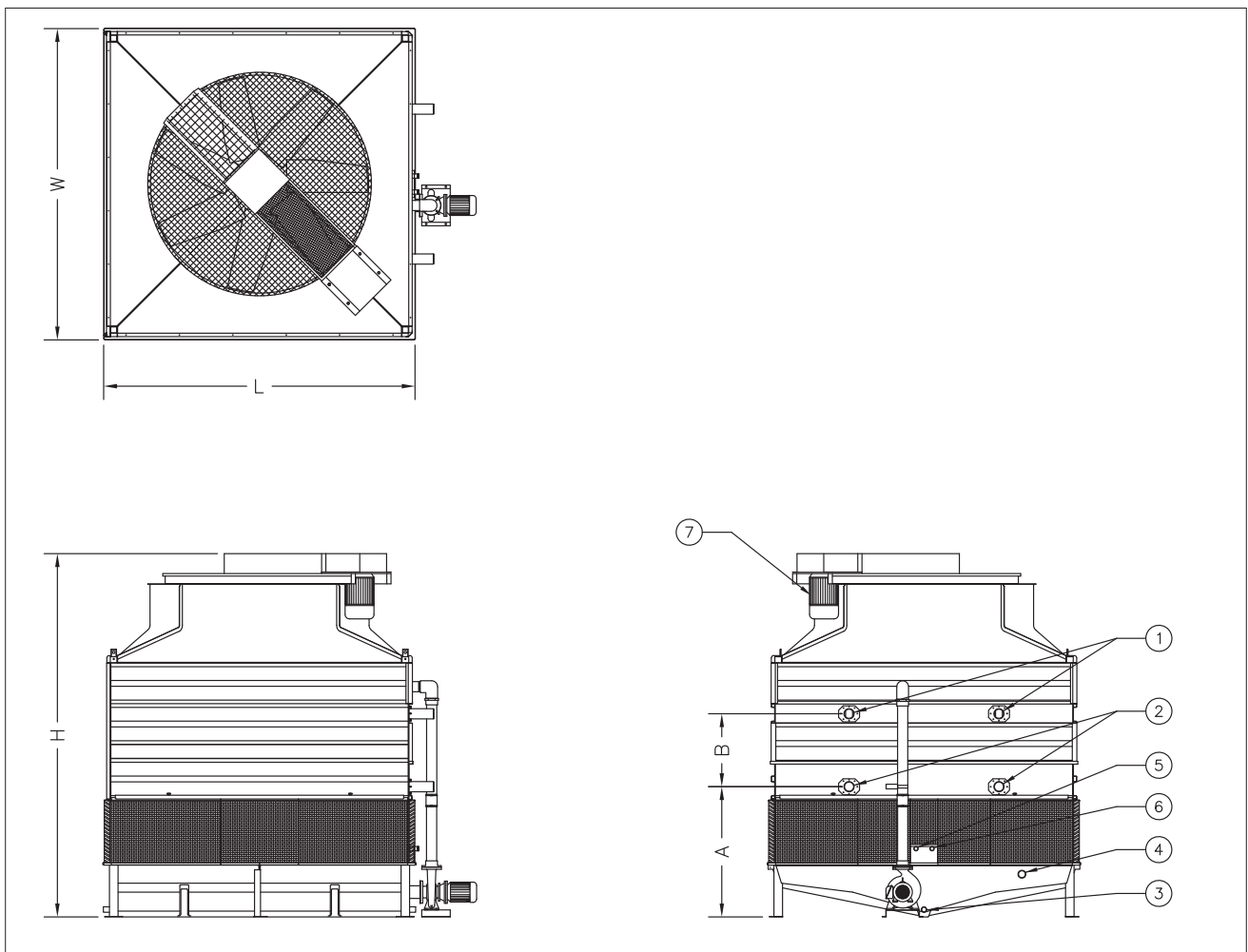

1. Fluid Inlet 100NB (Box Size 5x5, 6x6, 7x7 and 7x10.5 Have Single Coil Connection); 2. Fluid Outlet 100NB (Box Size 5x5, 6x6, 7x7 and 7x10.5 Have Single Coil Connection); 3. Drain; 4. Overflow; 5. Make-Up; 6. Quick Fill; 7. Fan Motor.

RCC Product Layout

> Counter Flow Product Layout

Evaporative condensers depend upon an adequate supply of fresh, ambient air to provide design capacity. Other important considerations such as the proximity to building air intakes or discharges also must be taken into account when selecting and designing the equipment site. This bulletin presents the design guidelines for siting counter flow products in several situations typically encountered by designers. All of the guidelines present recommended spacing requirements for good performance, but more liberal spacing should be provided where possible.

Also, note that as the size of an installation grows larger and larger, the total amount of heat being rejected to the atmosphere and the volume of discharge air increases accordingly -- to the point where the condensers virtually create their own environment. As a result, it becomes increasingly difficult to apply a set of correct general guidelines for every case. Consequently, it is recommended the layout of large counter flow product installations be referred to your local BAC representative or sales office for review.

As is typical of axial fan equipment, counter flow products are not generally suited for indoor or ducted applications. In such situations, centrifugal fan units are preferred.

General Considerations

When selecting the site for a counter flow product installation, consider the following factors;

1. Locate the unit to prevent the warm discharge air and any associated drift from being introduced into the fresh air intakes of the building(s) served by the unit or the intakes of neighbouring buildings.
2. Consider the potential for plume formation and its effect on the surroundings, such as large windowed areas, and pedestrian or vehicular traffic arteries.
3. Provide sufficient unobstructed space around the unit(s) to ensure an adequate supply of fresh, ambient air to the intake. Avoid situations where adjacent walls or structures might deflect some of the discharge airstream back into the air inlet (recirculation) or promote recirculation by generating high, downward air velocities in the vicinity of the intake. Also, avoid locations where building air intakes or exhausts, such as boiler stacks in the vicinity of the unit, might raise the inlet wet bulb temperature or starve the unit of air.
4. Provide adequate space around the unit for piping and proper servicing and maintenance as shown in Figure 1 and Table 1.
5. The top of the fan discharge cylinders must be at least level with and preferably higher than any adjacent walls or buildings.
6. For installations involving multiple units if cells are arranged with the air inlets facing, the dimensions given should be doubled for adequate air to each unit. Alternatively unit may need to be de-rated or air inlet height increased.

Figure 1

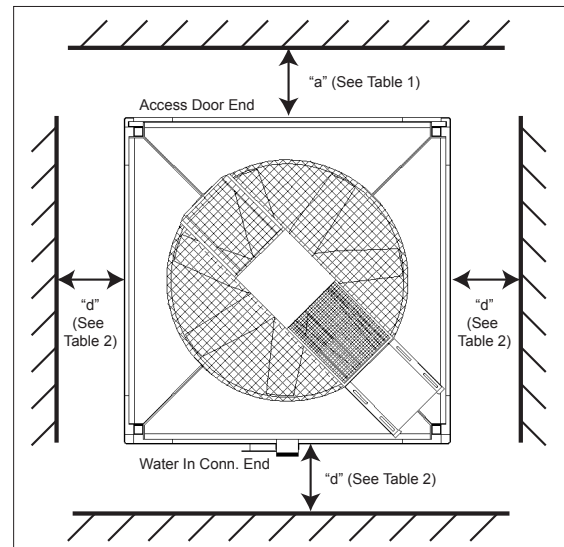



| Model Number | Box Size (ft) | Access Clearance "a" (m) |
|--------------|---------------|--------------------------|
| RCC-0505 | 5' x 5' | 1.5 |
| RCC-0606 | 6' x 6' | 1.5 |
| RCC-0707 | 7' x 7' | 1.5 |
| RCC-0808 | 8' x 8' | 1.5 |
| RCC-0909 | 9' x 9' | 1.5 |
| RCC-1010 | 10' x 10' | 1.8 |
| RCC-1111 | 11' x 11' | 1.8 |
| RCC-0710 | 7' x 10.5' | 1.5 |
| RCC-0812 | 8' x 12' | 1.5 |
| RCC-0913 | 9' x 13.5' | 1.5 |
| RCC-1015 | 10' x 15' | 1.8 |
| RCC-1116 | 11' x 16.5' | 1.8 |

Table 1: Access Clearance

> Layout Guidelines

The “Layout Guidelines” section of this bulletin describe several typical siting situations for counter flow products. If these guidelines do not cover a particular situation or if the layout criteria cannot be met, please refer the application to your local BAC representative or sales office for review. Please indicate prevailing wind direction, geographic orientation of the unit(s), and other factors such as large buildings and other obstructions that may influence layout decisions.

The most common counter flow product installations can be divided into three basic categories, adjacent to a wall/building, in a well, and behind louvres. The three situations are described below.

A. Adjacent to a Building or Wall

1. Unit Orientation:

When a counter flow product is located near a building wall, the preferred arrangement is to have the “short” side (if applicable) facing the adjacent wall or building.

2. Clearance:

Maintain clearance for access as outlined in Figure 1 & Table 1.

3. Air Inlet Requirements:

Should it ever be necessary to install a unit with the air inlet facing a wall, allow a minimum “d” dimension between the condenser air inlets and the wall as outlined in Figure 1 & Table 2.

| Model Number | Box Size (ft) | “d” (m) |
|--------------|---------------|---------|
| RCC-0505 | 5' x 5' | 0.9 |
| RCC-0606 | 6' x 6' | 0.9 |
| RCC-0707 | 7' x 7' | 0.9 |
| RCC-0808 | 8' x 8' | 1.1 |
| RCC-0909 | 9' x 9' | 1.4 |
| RCC-1010 | 10' x 10' | 1.4 |
| RCC-1111 | 11' x 11' | 1.5 |
| RCC-0710 | 7' x 10.5' | 1.2 |
| RCC-0812 | 8' x 12' | 1.4 |
| RCC-0913 | 9' x 13.5' | 1.6 |
| RCC-1015 | 10' x 15' | 1.8 |
| RCC-1116 | 11' x 16.5' | 1.8 |

Table 2: Minimum Air Inlet Distance “d” to Solid Wall or in Well

Note: Elevating the condenser has no effect on these “d” dimensions.

RCC Product Layout

B. The Well Installation

1. Unit Orientation:
When a counter flow product is located in a well
 - a) Centre the condenser within the enclosure so the supply air flows uniformly to all condenser air inlets.
 - b) The top of the fan discharge cylinder must be level with or higher than the adjacent walls.
2. Clearance:
Maintain clearance for access as outlined in Figure 1 & Table 1
3. Air Inlet Requirements:
To satisfy air inlet requirements in a well enclosure, allow a minimum "d" dimension between the condenser air inlets and the wall as outlined in Figure 2 & Table 2.

Figure 2 - Well Installation

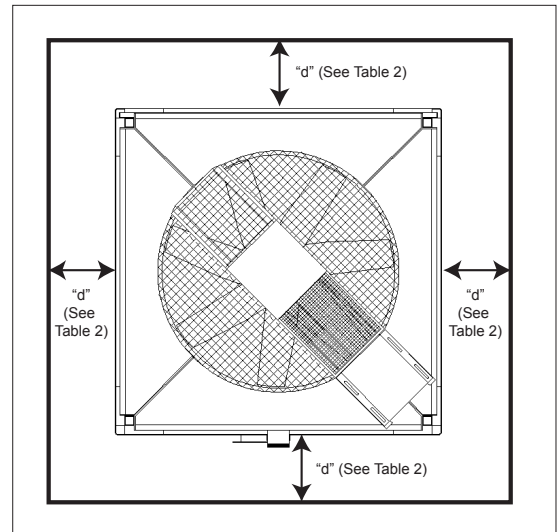

C. The Louvred or Slotted Wall Installations

Check to see if the layout meets the requirements for a well installation. If the criteria for the well location are met, the layout is satisfactory. If the layout does not satisfy the criteria for the well installation, analyse the layout as follows:

1. Unit Orientation:
When a counter flow product is located in a louvred enclosure
 - a) Arrange the condenser air intakes to directly face louvres.
 - b) The top of the fan discharge cylinder must be level with or higher than the adjacent walls.
2. Clearance:
Maintain clearance for access as outlined in Figure 1 & Table 1.

Figure 3 - Louvred enclosure installation

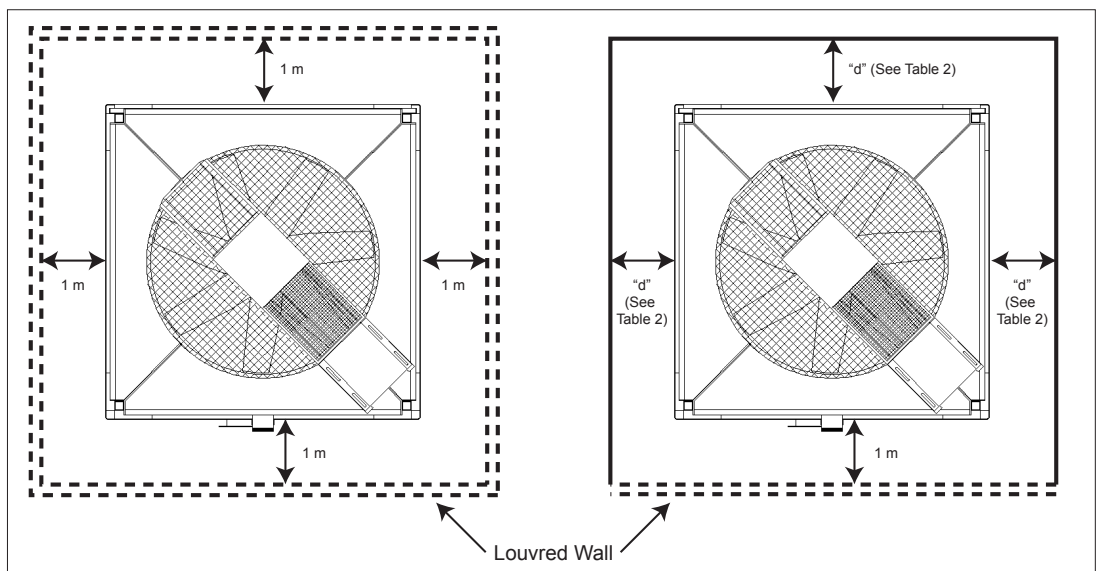



3. Air Inlet Requirements:

To satisfy air inlet requirements when a counter flow product is located in a louvred enclosure

- a) Maintain distances as shown in Figure 3.
- b) Louvres must provide at least 50% net free area.
- c) Determine the louvre or slot area required based on drawing the airflow through the net free area of the louvres at a velocity of 600 fpm or less. Calculate the louvre velocity as follows:

$$\text{Louvre Velocity} = \frac{\text{Total Unit Airflow (CFM)}}{\% \text{ louvre free area} \times \text{gross louvre area (ft}^2\text{)}} \leq 600 \text{ fpm (3m/s)}$$

Extending the louvred or slot area below the base of the condenser if needed is acceptable to achieve the minimum gross louvre area required. The condenser, however, must be elevated above the base of the enclosure to satisfy requirements 1b above. The usable louvred or slot area may also be extended beyond the ends of the condensers as shown in Figure 4.

Figure 4 - Usable louvred area

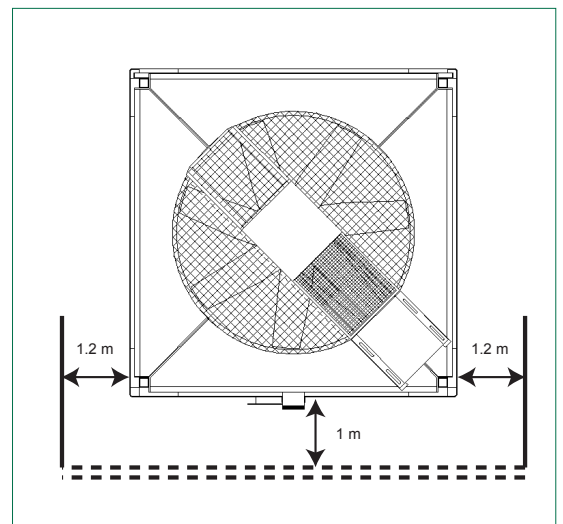

RCC Engineering Specifications

> 1.0 Evaporative Condenser

▶ 1.1 GENERAL:

Furnish and install ____factory assembled, induced draft, counter-flow, axial fan, evaporative condenser(s) with vertical air discharge, conforming in all aspects to the specifications and schedules as shown on the plans. Overall dimensions shall not exceed approximately ____m long x ____m wide x ____m high. The total connected fan horsepower shall not exceed ____kW. The condenser(s) shall be Baltimore Aircoil Company Model(s) _____.

▶ 1.2 THERMAL CAPACITY:

The evaporative condenser(s) shall be warranted by the manufacturer to have condensing capacity of ____kW heat rejection, operating with ____ refrigerant at ____°C condensing temperature and ____°C entering wet-bulb temperature.

▶ 1.3 QUALITY ASSURANCE:

The manufacturer shall have a Management System certified by an accredited registrar as complying with the requirements of ISO-9001 to ensure consistent quality of products and services. Manufacturers that are not ISO-9001 certified shall not be acceptable.

> 2.0 Construction Details

Casing

▶ 2.1 CORROSION RESISTANT STANDARD CONSTRUCTION:

Casing panels and supporting structure shall be constructed of superior strength pultruded composite. All pultruded composite components shall be moulded to exacting standards with UV resistant polyester resins such that the UV protection is afforded throughout the entire embodiment of the components as well as being an externally applied coating. All internal component supports shall be constructed of Type 304 Stainless Steel. All hardware joining steel parts shall be of Type 304 Stainless Steel.

▶ (ALTERNATE 2.1) CORROSION RESISTANT TYPE 316 STAINLESS STEEL CONSTRUCTION:

Casing panels and supporting structure shall be constructed of superior strength pultruded composite. All pultruded composite components shall be moulded to exacting standards with UV resistant polyester resins such that the UV protection is afforded throughout the entire embodiment of the components as well as being an externally applied coating. All internal component supports shall be constructed of Type 316 Stainless Steel. All hardware joining steel parts shall be of Type 316 Stainless Steel.

Fan Cowl and Mechanical Equipment

▶ 2.2 CORROSION RESISTANT STANDARD CONSTRUCTION:

Fan cowl sections shall be constructed of high performance Fibreglass Reinforced Polyester (FRP) and reinforced in critical areas. Sections shall be fastened together with Type 304 Stainless Steel hardware. All mechanical equipment supporting structure parts shall be constructed of ZAM coated steel. The fan shaft shall be of Type 316 Stainless Steel.

▶ (ALTERNATE 2.2) CORROSION RESISTANT TYPE 304 STAINLESS STEEL CONSTRUCTION:

Fan cowl sections shall be constructed of high performance Fibreglass Reinforced Polyester (FRP) and reinforced in critical areas. Sections shall be fastened together with Type 304 Stainless Steel hardware. All mechanical equipment supporting structure parts shall be constructed of Type 304 Stainless Steel. The fan shaft shall be of Type 316 Stainless Steel.

▶ (ALTERNATE 2.2) CORROSION RESISTANT TYPE 316 STAINLESS STEEL CONSTRUCTION:

Fan cowl sections shall be constructed of high performance Fibreglass Reinforced Polyester (FRP) and reinforced in critical areas. Sections shall be fastened together with Type 316 Stainless Steel hardware. All mechanical equipment supporting structure parts shall be constructed of Type 316 Stainless Steel. The fan shaft shall be of Type 316 Stainless Steel.



> 2.0 Construction Details cont.

Cold Water Basin

▶ **2.3 COLD WATER BASIN:**

The cold water basin shall be constructed of high performance Fibreglass Reinforced Polyester (FRP) and reinforced in critical areas. All connections and other steel parts in the wetted area shall be constructed of Type 304 Stainless Steel. Standard basin accessories shall include: a corrosion resistant make-up valve with large diameter plastic float for easy adjustment of the operating water level, removable anti-vortexing strainer with perforated openings sized smaller than the water distribution system nozzles.

▶ **(ALTERNATE 2.3)**

The cold water basin shall be constructed of high performance Fibreglass Reinforced Polyester (FRP) and reinforced in critical areas. All connections and other steel parts in the wetted area shall be constructed of Type 316 Stainless Steel. Standard basin accessories shall include: a corrosion resistant make-up valve with large diameter plastic float for easy adjustment of the operating water level, removable anti-vortexing strainer with perforated openings sized smaller than the water distribution system nozzles.

▶ **2.4 AIR INLET LOUVRE SCREENS:**

All louvres shall be constructed from PVC. Louvre sections shall be individually removable in sections of no greater than 48" wide, allowing for quick and easy access to any part of the cold water basin without the need for tools. Louvres shall prevent debris and sunlight from entering the cold water basin as well as preventing splash out. Louvres which require tools for removal shall not be an acceptable alternative.

▶ **2.5 CASING FIELD JOINT:**

The field joint shall be self aligning and require a minimum number of fasteners.

▶ **2.6 COIL CASING ASSEMBLY:**

The evaporative condenser(s) shall include a coil casing section consisting of a refrigerant condensing coil, a spray water distribution system, and drift eliminators as indicated by the manufacturer.

▶ **2.6.1 PRIME SURFACE COIL HDG CONSTRUCTION:**

The coil shall be fabricated of all prime surface steel at the manufacturers own facility, and hot-dip galvanised after fabrication. The coil shall be tested at 2750 kPa air pressure under water and be designed for low pressure drop.

▶ **(ALTERNATE 2.6.1) PRIME SURFACE COIL SST 304 CONSTRUCTION:**

The coil shall be fabricated of all prime surface Type 304 Stainless Steel at the manufacturers own facility. The coil shall be tested at 2750 kPa air pressure under water and be designed for low pressure drop.

▶ **(ALTERNATE 2.6.1) PRIME SURFACE COIL SST 316 CONSTRUCTION:**

The coil shall be fabricated of all prime surface Type 316 Stainless Steel at the manufacturers own facility. The coil shall be tested at 2750 kPa air pressure under water and be designed for low pressure drop.

▶ **2.6.2 WATER DISTRIBUTION SYSTEM:**

Water shall be distributed evenly over the coil to ensure complete wetting of the coil at all times by a water distribution system consisting of a header and spray branches of Schedule 40 PVC pipe with large orifice, non-clog plastic distribution nozzles. The spray nozzles shall be held in place by snap-in rubber grommets and the branches should be removable without tools or removal of branch supports, allowing quick removal of individual nozzles or complete branches for cleaning or flushing. Branches that require tools for removal or removal of branch supports shall not be an acceptable alternative.

▶ **2.6.3 DRIFT ELIMINATORS:**

Eliminators shall be constructed of PVC and shall be UV resistant and impervious to rot, decay and fungus or biological attacks. They shall consist of high efficiency three pass wave formed blades solvent welded into lightweight, easily removable sections. Drift loss shall be less than 0.002% of the circulated water flow as required by AS3666.

RCC Engineering Specifications

> 3.0 Mechanical Equipment

▶ 3.1 FAN(S):

Fan(s) shall be axial flow with glass reinforced polypropylene or glass reinforced polyamide blades selected to provide optimum condenser thermal performance with minimal sound levels. Air shall discharge through a fan cylinder designed for streamlined air entry and minimum tip clearance for maximum fan efficiency. The top of the fan cylinder shall be equipped with a non-sagging removable fan guard. The fan(s) and fan drive system, including the fan motor, shall be factory test-mounted and aligned to ensure reliable operation and ease of maintenance.

▶ 3.2 BEARINGS (BELT DRIVEN UNITS):

Fan(s) and shaft(s) shall be supported by heavy-duty, self-aligning, grease packed ball bearings with moisture proof seals and integral slinger collars, designed for L- 10 Life. Extended bearing lube lines shall be fitted for ease of maintenance.

▶ 3.3 FAN DRIVE:

The fan shall be either direct driven or belt driven. Where belts are used they shall be standard "A" or "B" section belts for ease of availability and be designed for 150% of the motor nameplate horsepower.

▶ 3.4 FAN MOTOR (DIRECT DRIVE UNITS):

Fan motor(s) shall be MEPS2 2006 compliant and be totally enclosed air over (TEAO), reversible, squirrel cage, ball bearing type, epoxy coated and be to IP66 protection rating. The motor(s) shall be mounted above the fan, protruding the top of the fan cowl for ease of access for lubrication and maintenance.

▶ (ALTERNATE 3.4) FAN MOTOR (BELT DRIVE UNITS):

Fan motor(s) shall be MEPS2 2006 compliant and be Totally Enclosed Fan Cooled (TEFC), reversible, squirrel cage, ball bearing type and be to IP55 protection rating. A removable protective cover shall protect the motor from the elements. Motor adjustments shall be made from the exterior of the unit. Internally mounted motors shall not be an acceptable alternative.

> 4.0 Access

▶ 4.1 CONDENSER ACCESS:

One full side of the casing shall be removable to provide full and open access to all internal condenser components for inspection, maintenance and cleaning. The access panel shall be retained by easily removable knobs and when removed shall not compromise structural integrity of the condenser. Additionally a second access panel of similar design shall be provided on the coil connection end of the condenser to provide access to the coil return bends for inspection and cleaning.

> 5.0 Sound

▶ 5.1 SOUND LEVEL:

Sound rating data are available for all RCC evaporative condensers which can be used to calculate sound levels generated by the condenser. When making such calculations, the designer must take into account the effects of geometry of the condenser installations as well as the distance and direction from the condenser to noise sensitive areas.



> 6.0 Accessories

▶ 6.1 BASIN HEATER(S):

The condenser cold water basin shall be provided with electric heater(s) to prevent freezing in low ambient conditions. The heater(s) shall be _____kW _____V/____phase/___Hz electric and shall be provided with a thermostat.

▶ 6.2 BASIN WATER LEVEL CONTROL:

The condenser manufacturer shall provide an Electric Water Level Control (EWLC) system. The system shall consist of an electric float switch with stainless steel stilling chamber and a brass body solenoid valve in quantities and locations as indicated on the drawings. The system shall be capable of handling water pressures ranging from 0.3 – 10 bar and accept 240V/1PH/50Hz power supply. Electrical enclosures shall be of IP65 protection and the float switch shall be of single pole single throw type. The valve shall have female BSP threaded connections and shall be slow closing and of a water hammer damped type.

▶ (ALTERNATIVE 6.2) BASIN WATER LEVEL CONTROL:

A liquid level control device shall be fitted externally to the cooling tower basin to maintain adequate water level through a pilot operated valve. The device shall consist of an externally mounted stilling chamber with float mechanism and controller valve, and a pilot operated make up valve fitted to the condenser make up connection.

▶ 6.3 VIBRATION CUTOFF SWITCH:

A mechanical local reset vibration switch shall be fitted to the mechanical assembly of the condenser. It shall be designed to trip at a point so as not to cause damage to the condenser. The switch time delay and trip point shall be preset to typical values. Adjustment for these settings shall be available.

▶ (ALTERNATIVE 6.3) VIBRATION CUTOFF SWITCH:

An electronic remote reset vibration switch with contact for BAS monitoring shall be fitted to the mechanical assembly of the condenser. Wiring shall be by the installing contractor. The electronic vibration cut out switch shall be set to trip at a point so as not to cause damage to the condenser. The switch time and trip point shall be preset to typical values. Adjustment of these settings shall be available.

▶ 6.4 BASIN SWEEPER PIPING:

The cold water basin of the condenser shall be equipped with PVC basin sweeper piping suitable for use with a filter or separator (supplied by others).

▶ 6.5 EXTENDED FAN COWL:

The unit shall be equipped with a ZAM cylinder fitted to the top of the fan cowl suitable for connecting duct work.

▶ 6.6 EXTERNAL ACCESS – ROOF DECK ACCESS POD:

Provide an external ZAM access pod at the roof deck level of the unit(s) to allow access to the drive system. A hot-dip galvanised ladder from unit footing height to the pod at 15 deg to vertical shall be included. Field installation is by others. The installation shall be designed in accordance with AS 1657-1992.

> 7.0 Equipment Controls

▶ 7.1 VARIABLE SPEED DRIVE(S):

A Variable Speed Drive (VSD) shall be provided for each fan motor. It shall be factory mounted externally to the unit and be pre-wired and set to the required duty. The supplier of the VSD shall be the manufacturer of the evaporative cooling equipment. The VSD shall have 98% basic energy efficiency, sleep mode, automatic energy optimisation, flow compensation, and have a removable control panel. The drive shall be to IP66 protection rating and be capable of running at full load at temperatures up to 50°C.



**BALTIMORE
AIRCOIL AUSTRALIA**

COOLING TOWERS

CLOSED CIRCUIT COOLING TOWERS

ICE THERMAL STORAGE

EVAPORATIVE CONDENSERS

HYBRID PRODUCTS

PARTS & SERVICES



www.BaltimoreAircoil.com.au

120 Wisemans Ferry Road, Somersby NSW 2250 > Telephone (Australia): 1300.134.622 > Telephone (New Zealand): 0800.225.842