

# CXVB Engineering Data

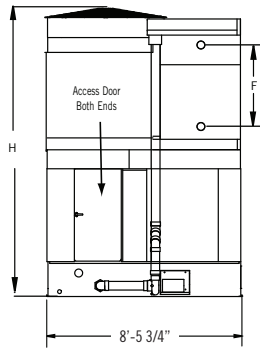

**Connection Side:**  
CXVB 8' x 6', 8' x 9', 8' x 12' and 8' x 18' Units

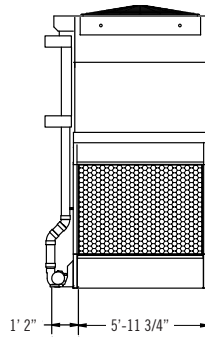

**Air Inlet End:**  
CXVB 8' x 6' Units

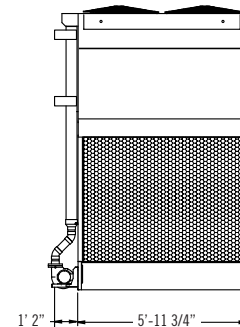

**Air Inlet End:**  
CXVB 8' x 9' Units

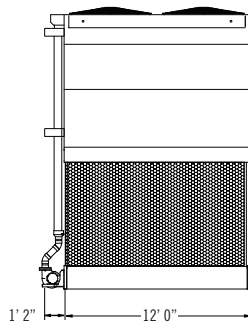

**Air Inlet End:**  
CXVB 8' x 12' Units

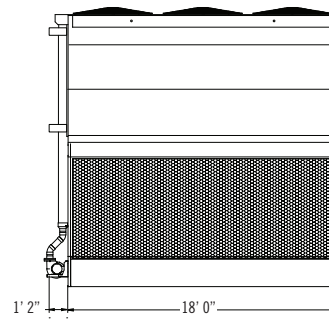

**Air Inlet End:**  
CXVB 8' x 18' Units



## NOTES:

1. Model number denotes R-717 capacity in evaporator tons at a 96.3°F condensing temperature, a 20°F suction temperature, and a 78°F entering wet-bulb temperature.
2. R-22 tons are at a 105°F condensing temperature, a 40°F suction temperature, and a 78°F entering wet-bulb temperature.
3. Operating weight is for the unit with the water level at the overflow level and with the coil charged with R-717.
4. The R-22 operating charge is 1.93 times the R-717 charge; R-134a is 1.98 times.
5. Drain size is based on a bottom connection.
6. For R-22 and R-134a, the coil connection quantity may double.
7. Standard make-up, drain, and overflow connections are MPT.
8. Coil inlet and outlet connections are beveled for welding.

**Do not use for construction.** Refer to factory certified dimensions. This catalog includes data current at the time of publication, which should be reconfirmed at the time of purchase.



**NOTE:** Up-to-date engineering data, free product selection software, and more can be found at [www.BaltimoreAircoil.com](http://www.BaltimoreAircoil.com).

Nom. Box Size	Model Number <sup>(1)</sup>	Base Heat Rejection (MBH)	R-22 Tons <sup>(2)</sup>	Fan Motor (HP)	Airflow Rate (CFM)	Pump Motor (HP)	Spray Flow Rate (GPM)	Approximate Weight (lbs)			R-717 Operating Charge <sup>(4)</sup> (lbs)	Internal Coil Volume (ft <sup>3</sup> )	Remote Sump				
								Ship Weight	Heaviest Section	Oper. Weight <sup>(3)</sup>			Drain Size <sup>(5)</sup> (in)	Volume Req. (gal)	Approx. Oper. Weight (lbs)	F	H
8' x 6'	CXVB-75-0806-3	1,550	95	3	22,200	2	290	4,830	2,870	7,410	54	6	6	290	7,300	3'-7"	12'-7"
	CXVB-87-0806-3	1,798	110	3	24,300			5,590	3,160	8,190	71	8			8,070	3'-7"	15'-3"
	CXVB-94-0806-3	1,943	119	3	20,400			7,120	5,050	9,810	161	18			9,700	6'-4"	15'-5"
	CXVB-95-0806-5	1,964	120	5	28,800			5,600	3,170	8,200	71	8			8,080	3'-7"	15'-3"
	CXVB-102-0806-7.5	2,109	129	7.5	32,900			5,630	3,200	8,230	71	8			8,120	3'-7"	15'-3"
	CXVB-106-0806-3	2,191	134	3	23,400			7,580	5,050	10,270	161	18			10,150	6'-4"	18'-1"
	CXVB-111-0806-10	2,295	141	10	35,900			5,950	3,500	8,570	89	10			8,450	3'-7"	15'-3"
	CXVB-117-0806-5	2,419	148	5	27,700			7,590	5,060	10,280	161	18			10,160	6'-4"	18'-1"
	CXVB-123-0806-10	2,543	156	10	35,500			6,660	4,180	9,290	107	12			9,180	6'-6"	18'-1"
	CXVB-137-0806-15	2,832	173	15	39,900			7,650	5,120	10,330	161	18			10,220	6'-6"	18'-1"
8' x 8'	CXVB-113-0809-3	2,336	143	3	31,200	5	500	7,040	3,760	11,010	80	9	8	550	10,790	3'-7"	15'-1"
	CXVB-124-0809-5	2,563	157	5	37,000			7,060	3,770	11,020	80	9			10,800	3'-7"	15'-2"
	CXVB-126-0809-3	2,605	159	3	26,700			9,150	6,310	13,240	214	24			13,030	6'-6"	15'-5"
	CXVB-134-0809-7.5	2,770	170	7.5	42,300			7,090	3,800	11,050	80	9			10,840	3'-7"	15'-3"
	CXVB-138-0809-3	2,853	175	3	30,200			9,270	5,880	13,340	188	21			13,130	6'-6"	17'-11"
	CXVB-138-0809-5	2,853	175	5	36,200			7,950	4,620	11,960	134	15			11,750	3'-7"	15'-2"
	CXVB-141-0809-3	2,915	178	3	29,800			10,170	6,730	14,290	241	27			14,080	6'-6"	18'-1"
	CXVB-144-0809-7.5	2,977	182	7.5	41,900			7,540	4,230	11,530	107	12			11,310	3'-7"	15'-1"
	CXVB-152-0809-5	3,142	192	5	35,700			9,290	5,890	13,350	188	21			13,140	6'-6"	17'-11"
	CXVB-158-0809-5	3,266	200	5	35,300			10,180	6,750	14,300	241	27			14,090	6'-6"	17'-11"
	CXVB-163-0809-7.5	3,370	206	7.5	41,200			8,870	5,500	12,910	161	18			12,700	6'-6"	17'-11"
	CXVB-190-0809-15	3,928	241	15	51,500			9,410	6,010	13,480	188	21			13,270	6'-6"	17'-11"
	CXVB-207-0809-20	4,279	262	20	56,000			10,330	6,890	14,450	241	27			14,240	6'-6"	17'-11"
	8' x 12'	CXVB-172-0812-7.5	3,556	218	7.5			53,500	5	719	8,570	4,570			13,910	107	12
CXVB-195-0812-10		4,031	247	10	58,000	9,170	5,150	14,550			143	16	14,340	3'-7"	15'-3"		
CXVB-204-0812-7.5		4,217	258	7.5	44,500	12,030	8,500	17,590			322	36	17,370	6'-4"	15'-5"		
CXVB-207-0812-15		4,279	262	15	66,400	9,250	5,220	14,630			143	16	14,420	3'-7"	15'-3"		
CXVB-216-0812-7.5		4,465	273	7.5	51,700	10,920	6,810	16,370			214	24	16,150	6'-4"	18'-1"		
CXVB-217-0812-15		4,486	275	15	65,700	9,850	5,790	15,260			179	20	15,050	3'-7"	15'-3"		
CXVB-221-0812-7.5		4,569	280	7.5	51,100	11,810	7,650	17,310			268	30	17,090	6'-4"	18'-1"		
CXVB-226-0812-7.5		4,672	286	7.5	50,800	12,690	8,500	18,250			322	36	18,030	6'-4"	18'-1"		
CXVB-227-0812-20		4,693	287	20	72,300	9,870	5,810	15,280			179	20	15,070	3'-7"	15'-3"		
CXVB-237-0812-10		4,899	300	10	56,300	11,820	7,670	17,320			268	30	17,110	6'-4"	18'-1"		
CXVB-238-0812-15		4,920	301	15	65,200	10,910	6,810	16,360			214	24	16,150	6'-6"	18'-1"		
CXVB-241-0812-10		4,982	305	10	55,900	12,700	8,510	18,260			322	36	18,050	6'-4"	18'-1"		
CXVB-259-0812-20		5,354	328	20	71,200	11,530	7,390	17,010			250	28	16,800	6'-6"	18'-1"		
CXVB-270-0812-25		5,581	342	25	76,100	12,180	8,010	17,700			286	32	17,480	6'-6"	18'-1"		
CXVB-284-0812-30		5,871	359	30	80,600	12,790	8,600	18,350			322	36	18,140	6'-6"	18'-1"		
8' x 18'		CXVB-248-0818-15	5,127	314	(1) 10 & (1) 5	89,700	7.5	859			12,400	6,660	20,500	161	18	10	750
	CXVB-268-0818-15	5,540	339	(1) 10 & (1) 5	88,400	13,350			7,570	21,500	214	24	21,240	3'-7"	15'-9"		
	CXVB-281-0818-15	5,809	356	(1) 10 & (1) 5	87,600	14,300			8,470	22,500	268	30	22,240	3'-7"	15'-9"		
	CXVB-310-0818-15	6,408	392	(1) 10 & (1) 5	86,900	15,830			9,930	24,090	322	36	23,830	6'-6"	18'-7"		
	CXVB-321-0818-15	6,636	406	(1) 10 & (1) 5	86,900	15,940			10,030	24,200	322	36	23,940	6'-4"	18'-7"		
	CXVB-327-0818-15	6,760	414	(1) 10 & (1) 5	85,200	18,680			12,640	27,100	483	53	26,840	6'-6"	18'-7"		
	CXVB-329-0818-22.5	6,801	416	(1) 15 & (1) 7.5	99,500	15,950			10,040	24,210	322	36	23,950	6'-6"	18'-7"		
	CXVB-342-0818-15	7,070	433	(1) 10 & (1) 5	85,200	18,780			12,740	27,200	483	53	26,940	6'-4"	18'-7"		
	CXVB-345-0818-30	7,132	437	(1) 20 & (1) 10	109,500	15,980			10,070	24,240	322	36	23,980	6'-6"	18'-7"		
	CXVB-357-0818-22.5	7,380	452	(1) 15 & (1) 7.5	98,400	17,470			11,490	25,820	402	44	25,550	6'-4"	18'-7"		
	CXVB-373-0818-30	7,711	472	(1) 20 & (1) 10	108,300	17,510			11,530	25,850	402	44	25,590	6'-4"	18'-7"		
	CXVB-387-0818-30	8,000	490	(1) 20 & (1) 10	107,300	18,930			12,880	27,350	483	53	27,090	6'-4"	18'-7"		
	CXVB-409-0818-45	8,455	518	(1) 30 & (1) 15	122,800	19,090			13,030	27,510	483	53	27,250	6'-4"	18'-7"		

# CXVB Engineering Data

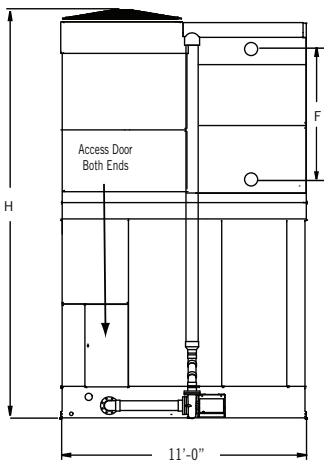

**Connection Side:**  
CXVB 12' x 12' and 12' x 18' Units

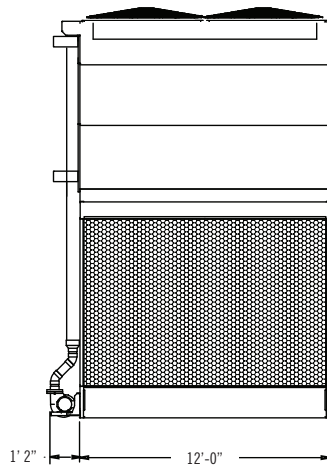

**Air Inlet End:**  
CXVB 12' x 12' Units

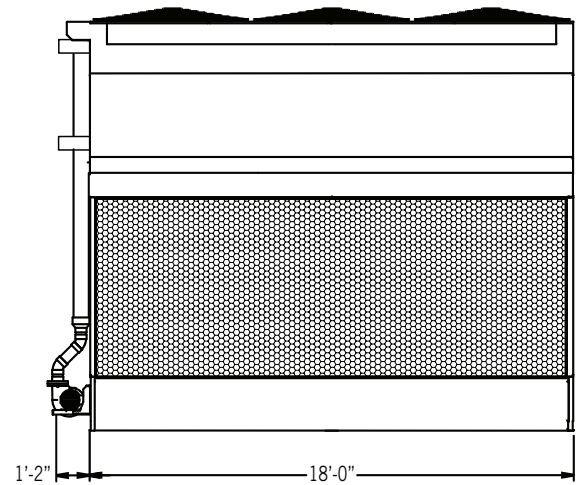

**Air Inlet End:**  
CXVB 12' x 18' Units



## NOTES:

1. Model number denotes R-717 capacity in evaporator tons at a 96.3°F condensing temperature, a 20°F suction temperature, and a 78°F entering wet-bulb temperature.
2. R-22 tons are at a 105°F condensing temperature, a 40°F suction temperature, and a 78°F entering wet-bulb temperature.
3. Operating weight is for the unit with the water level at the overflow level and with the coil charged with R-717.
4. The R-22 operating charge is 1.93 times the R-717 charge; R-134a is 1.98 times.
5. Drain size is based on a bottom connection.
6. For R-22 and R-134a, the coil connection quantity may double.
7. Standard make-up, drain, and overflow connections are MPT.
8. Coil inlet and outlet connections are beveled for welding.

**Do not use for construction.** Refer to factory certified dimensions. This catalog includes data current at the time of publication, which should be reconfirmed at the time of purchase.



Nom. Box Size	Model Number <sup>(1)</sup>	Base Heat Rejection (MBH)	R-22 Tons <sup>(2)</sup>	Fan Motor (HP)	Airflow Rate (CFM)	Pump Motor (HP)	Spray Flow Rate (GPM)	Approximate Weight (lbs)			R-717 Operating Charge <sup>(4)</sup> (lbs)	Internal Coil Volume (ft <sup>3</sup> )	Remote Sump			F	H
								Ship Weight	Heaviest Section	Oper. Weight <sup>(3)</sup>			Drain Size <sup>(5)</sup> (in)	Volume Req. (gal)	Approx. Oper. Weight (lbs)		
12' x 12'	CXVB-237-1212-10	4,899	300	10	71,900	7.5	859	10,830	6,110	18,570	177	20	10	750	18,310	3'-7"	16'-7"
	CXVB-264-1212-10	5,457	334	10	70,400			12,780	7,960	20,640	294	33			20,380	3'-7"	16'-7"
	CXVB-285-1212-15	5,892	361	15	80,600			12,860	8,040	20,720	294	33			20,460	3'-7"	16'-7"
	CXVB-297-1212-10	6,140	376	10	69,800			14,370	9,480	22,290	353	39			22,030	6'-4"	19'-6"
	CXVB-299-1212-10	6,181	378	10	68,800			16,250	11,260	24,280	471	52			24,020	6'-6"	19'-6"
	CXVB-302-1212-20	6,243	382	20	88,700			12,880	8,060	20,750	294	33			20,480	3'-7"	16'-7"
	CXVB-306-1212-10	6,326	387	10	69,000			15,830	10,870	23,840	442	49			23,580	6'-4"	19'-6"
	CXVB-314-1212-15	6,491	397	15	79,900			14,380	9,490	22,300	353	39			22,030	6'-6"	19'-6"
	CXVB-315-1212-10	6,512	399	10	68,300			17,290	12,260	25,390	530	58			25,120	6'-4"	19'-6"
	CXVB-327-1212-15	6,760	414	15	78,700			16,330	11,340	24,360	471	52			24,100	6'-6"	19'-6"
	CXVB-341-1212-20	7,049	432	20	87,300			15,380	10,440	23,350	412	45			23,090	6'-6"	19'-6"
	CXVB-341-1212-15	7,049	432	15	78,200			17,370	12,340	25,470	530	58			25,200	6'-4"	19'-6"
	CXVB-355-1212-25	7,339	449	25	94,100			15,430	10,490	23,410	412	45			23,150	6'-6"	19'-6"
	CXVB-370-1212-25	7,649	468	25	93,600			15,990	11,020	24,000	442	49			23,740	6'-4"	19'-6"
	CXVB-381-1212-30	7,876	482	30	98,500			17,400	12,370	25,500	530	58			25,240	6'-6"	19'-6"
	CXVB-393-1212-30	8,124	497	30	98,500			17,470	12,430	25,570	530	58			25,310	6'-4"	19'-6"
CXVB-411-1212-40	8,496	520	40	109,500	16,320	11,330	24,320	442	49	24,060	6'-4"	19'-6"					
12' x 18'	CXVB-360-1218-15	7,442	456	(1) 10 & (1) 5	108,600	10	1,300	15,940	8,990	27,690	265	29	12	1,085	27,200	3'-7"	17'-1"
	CXVB-403-1218-15	8,331	510	(1) 10 & (1) 5	108,100			19,130	12,020	31,050	442	49			30,570	3'-7"	17'-1"
	CXVB-437-1218-22.5	9,034	553	(1) 15 & (1) 7.5	123,800			19,250	12,130	31,170	442	49			30,680	3'-7"	17'-1"
	CXVB-444-1218-15	9,178	562	(1) 10 & (1) 5	105,200			21,280	14,070	33,290	530	58			32,800	6'-6"	20'-0"
	CXVB-457-1218-15	9,447	578	(1) 10 & (1) 5	105,200			21,430	14,210	33,440	530	58			32,950	6'-4"	20'-0"
	CXVB-459-1218-15	9,488	581	(1) 10 & (1) 5	103,800			24,470	17,110	36,660	706	78			36,170	6'-6"	20'-0"
	CXVB-467-1218-15	9,654	591	(1) 10 & (1) 5	103,000			25,960	18,530	38,240	795	87			37,750	6'-6"	20'-0"
	CXVB-482-1218-22.5	9,964	610	(1) 15 & (1) 7.5	120,400			21,460	14,240	33,470	530	58			32,990	6'-6"	20'-0"
	CXVB-483-1218-15	9,985	611	(1) 10 & (1) 5	103,000			26,110	18,660	38,380	795	87			37,890	6'-4"	20'-0"
	CXVB-513-1218-22.5	10,605	649	(1) 15 & (1) 7.5	119,200			23,880	16,550	36,030	662	73			35,540	6'-4"	20'-0"
	CXVB-525-1218-22.5	10,853	665	(1) 15 & (1) 7.5	117,900			26,220	18,770	38,500	795	87			38,010	6'-4"	20'-0"
	CXVB-525-1218-30	10,853	665	(1) 20 & (1) 10	132,600			21,580	14,350	33,590	530	58			33,100	6'-4"	20'-0"
	CXVB-545-1218-30	11,266	690	(1) 20 & (1) 10	131,200			23,920	16,580	36,060	662	73			35,570	6'-4"	20'-0"
	CXVB-567-1218-37.5	11,721	718	(1) 25 & (1) 15	141,300			23,980	16,640	36,120	662	73			35,630	6'-4"	20'-0"
	CXVB-581-1218-37.5	12,010	735	(1) 25 & (1) 15	139,800			26,310	18,860	38,590	795	87			38,100	6'-4"	20'-0"
	CXVB-601-1218-45	12,424	761	(1) 30 & (1) 15	148,500			26,420	18,960	38,690	795	87			38,200	6'-4"	20'-0"
	CXVB-628-1218-60	12,982	795	(1) 40 & (1) 20	165,300			24,400	17,040	36,550	662	73			36,060	6'-4"	20'-0"
	CXVB-643-1218-60	13,292	814	(1) 40 & (1) 20	163,500			26,740	19,270	39,020	795	87			38,530	6'-4"	20'-0"

# CXVB Engineering Data

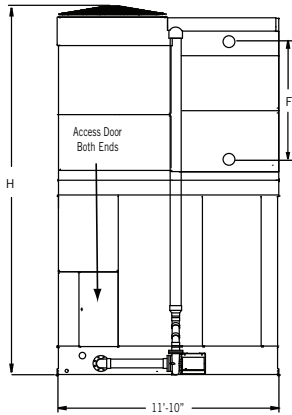

**Connection Side:**  
CXVB 12' x 24' and 12' x 36' Units

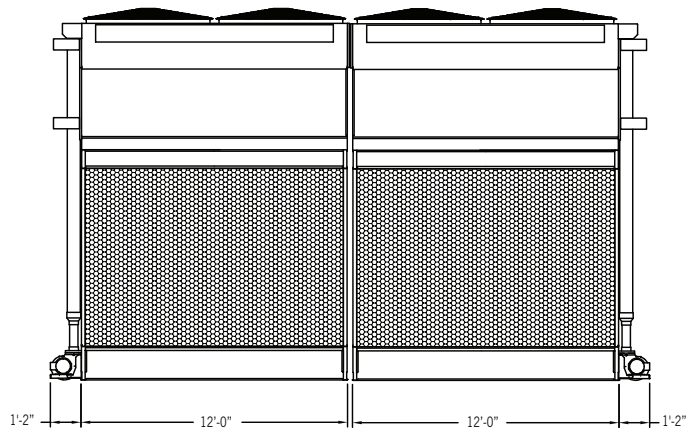

**Air Inlet End:**  
CXVB 12' x 24' Units

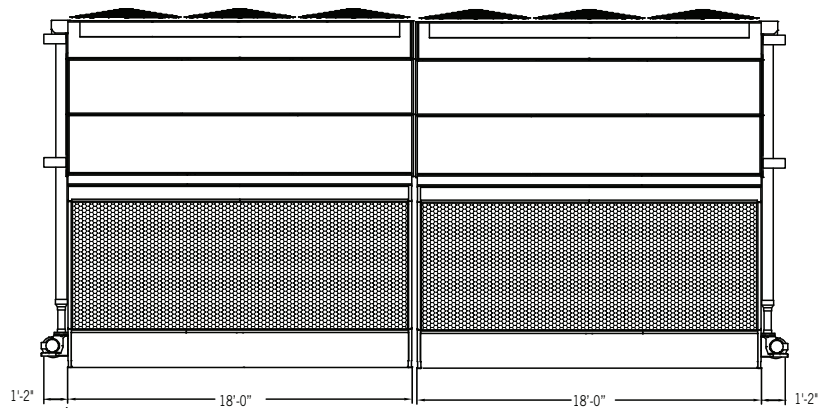

**Air Inlet End:**  
CXVB 12' x 36' Units



## NOTES:

1. Model number denotes R-717 capacity in evaporator tons at a 96.3°F condensing temperature, a 20°F suction temperature, and a 78°F entering wet-bulb temperature.
2. R-22 tons are at a 105°F condensing temperature, a 40°F suction temperature, and a 78°F entering wet-bulb temperature.
3. Operating weight is for the unit with the water level at the overflow level and with the coil charged with R-717.
4. The R-22 operating charge is 1.93 times the R-717 charge; R-134a is 1.98 times.
5. Drain size is based on a bottom connection.
6. For R-22 and R-134a, the coil connection quantity may double.
7. Standard make-up, drain, and overflow connections are MPT.
8. Coil inlet and outlet connections are beveled for welding.

**Do not use for construction.** Refer to factory certified dimensions. This catalog includes data current at the time of publication, which should be reconfirmed at the time of purchase.



Nom. Box Size	Model Number <sup>(1)</sup>	Base Heat Rejection (MBH)	R-22 Tons <sup>(2)</sup>	Fan Motor (HP)	Airflow Rate (CFM)	Pump Motor (HP)	Spray Flow Rate (GPM)	Approximate Weight (lbs)			R-717 Operating Charge <sup>(4)</sup> (lbs)	Internal Coil Volume (ft <sup>3</sup> )	Remote Sump				
								Ship Weight	Heaviest Section	Oper. Weight <sup>(3)</sup>			Drain Size <sup>(5)</sup> (in)	Volume Req. (gal)	Approx. Oper. Weight (lbs)	F	H
12' x 24'	CXVB-473-1224-20	9,778	599	(2) 10	143,700	(2) 7.5	1,718	21,660	6,110	37,160	354	40	(2) 10	1,500	36,620	3'-7"	16'-7"
	CXVB-528-1224-20	10,915	668	(2) 10	140,700			25,560	7,960	41,280	588	66			40,750	3'-7"	16'-7"
	CXVB-571-1224-30	11,804	723	(2) 15	161,100			25,720	8,040	41,440	588	66			40,910	3'-7"	16'-7"
	CXVB-595-1224-20	12,300	753	(2) 10	139,500			28,740	9,480	44,580	706	78			44,050	6'-4"	19'-6"
	CXVB-598-1224-20	12,362	757	(2) 10	137,500			32,490	11,260	48,560	942	104			48,040	6'-6"	19'-6"
	CXVB-604-1224-40	12,486	765	(2) 20	177,300			25,760	8,060	41,500	588	66			40,960	3'-7"	16'-7"
	CXVB-612-1224-20	12,651	775	(2) 10	138,000			31,660	10,870	47,680	884	98			47,150	6'-4"	19'-6"
	CXVB-629-1224-30	13,003	796	(2) 15	159,700			28,750	9,490	44,600	706	78			44,060	6'-6"	19'-6"
	CXVB-630-1224-20	13,023	797	(2) 10	136,600			34,570	12,260	50,780	1,060	116			50,240	6'-4"	19'-6"
	CXVB-655-1224-30	13,540	829	(2) 15	157,400			32,650	11,340	48,720	942	104			48,200	6'-6"	19'-6"
	CXVB-682-1224-30	14,098	863	(2) 15	156,400			34,730	12,340	50,940	1,060	116			50,400	6'-6"	19'-6"
	CXVB-682-1224-40	14,098	863	(2) 20	174,600			30,750	10,440	46,700	824	90			46,180	6'-4"	19'-6"
	CXVB-711-1224-50	14,698	900	(2) 25	188,100			30,860	10,490	46,820	824	90			46,290	6'-6"	19'-6"
	CXVB-739-1224-50	15,277	935	(2) 25	187,200			31,980	11,020	48,000	884	98			47,470	6'-4"	19'-6"
	CXVB-762-1224-60	15,752	965	(2) 30	197,000			34,800	12,370	51,000	1,060	116			50,470	6'-6"	19'-6"
	CXVB-786-1224-60	16,248	995	(2) 30	197,000			34,940	12,430	51,140	1,060	116			50,610	6'-4"	19'-6"
CXVB-821-1224-80	16,972	1,039	(2) 40	219,000	32,630	11,330	48,640	884	98	48,120	6'-4"	19'-6"					
12' x 36'	CXVB-719-1236-30	14,863	910	(2) 10 & (2) 5	217,200	(2) 10	2,600	31,880	8,990	55,380	530	58	(2) 12	2,170	54,390	3'-7"	17'-1"
	CXVB-806-1236-30	16,662	1,020	(2) 10 & (2) 5	216,200			38,260	12,020	62,100	884	98			61,130	3'-7"	17'-1"
	CXVB-875-1236-45	18,088	1,108	(2) 15 & (2) 7.5	247,500			38,490	12,130	62,340	884	98			61,360	3'-7"	17'-1"
	CXVB-888-1236-30	18,357	1,124	(2) 10 & (2) 5	210,400			42,560	14,070	66,580	1,060	116			65,600	6'-6"	20'-0"
	CXVB-914-1236-30	18,894	1,157	(2) 10 & (2) 5	210,400			42,860	14,210	66,880	1,060	116			65,900	6'-4"	20'-0"
	CXVB-918-1236-30	18,977	1,162	(2) 10 & (2) 5	207,600			48,940	17,110	73,320	1,412	156			72,330	6'-6"	20'-0"
	CXVB-933-1236-30	19,287	1,181	(2) 10 & (2) 5	206,000			51,920	18,530	76,480	1,590	174			75,500	6'-6"	20'-0"
	CXVB-964-1236-45	19,928	1,220	(2) 15 & (2) 7.5	240,800			42,920	14,240	66,940	1,060	116			65,970	6'-6"	20'-0"
	CXVB-966-1236-30	19,969	1,223	(2) 10 & (2) 5	206,000			52,210	18,660	76,760	1,590	174			75,780	6'-4"	20'-0"
	CXVB-1027-1236-45	21,230	1,300	(2) 15 & (2) 7.5	238,400			47,760	16,550	72,060	1,324	146			71,070	6'-4"	20'-0"
	CXVB-1049-1236-45	21,685	1,328	(2) 15 & (2) 7.5	235,800			52,440	18,770	77,000	1,590	174			76,010	6'-4"	20'-0"
	CXVB-1049-1236-60	21,685	1,328	(2) 20 & (2) 10	265,100			43,160	14,350	67,180	1,060	116			66,200	6'-4"	20'-0"
	CXVB-1089-1236-60	22,512	1,378	(2) 20 & (2) 10	262,400			47,830	16,580	72,120	1,324	146			71,140	6'-4"	20'-0"
	CXVB-1134-1236-75	23,442	1,435	(2) 25 & (2) 15	282,600			47,950	16,640	72,240	1,324	146			71,260	6'-4"	20'-0"
	CXVB-1161-1236-75	24,000	1,470	(2) 25 & (2) 15	279,500			52,620	18,860	77,180	1,590	174			76,200	6'-4"	20'-0"
	CXVB-1202-1236-90	24,848	1,522	(2) 30 & (2) 15	297,000			52,830	18,960	77,380	1,590	174			76,400	6'-4"	20'-0"
	CXVB-1257-1236-120	25,985	1,591	(2) 40 & (2) 20	330,500			48,800	17,040	73,100	1,324	146			72,110	6'-4"	20'-0"
	CXVB-1287-1236-120	26,605	1,629	(2) 40 & (2) 20	326,900			53,480	19,270	78,040	1,590	174			77,050	6'-4"	20'-0"

# CXVT and CXVB Structural Support

The recommended support arrangement for CXVT and CXVB Evaporative Condensers consists of parallel structural members positioned per the tables below. In addition to providing adequate support, the members also serve to raise the unit above any solid foundation to ensure access to the bottom of the unit. To support CXVT on columns or in an alternate arrangement not shown here, consult your local BAC Representative.

## NOTES:

- Support members and anchor bolts shall be designed, furnished, and installed by others.
- Design of support members and anchor bolts shall be in accordance with the strength and serviceability requirements of the applicable building code and project specifications.
- Support members shall be level at the top.
- Refer to the certified unit support drawing for loading and additional support requirements.
- If vibration isolation (provided by others) is used, the isolators should be located under a structural base that complies with one of the recommended support arrangements. Contact your local BAC Representative for all other isolator configurations.
- CXVB 8.5' and 12' models can be cantilevered up to 2' on the side opposite the air inlet.

## CXVT SINGLE CELL STANDARD ONLY

Model Number	A	B	C	D
CXVT-x-1224-x and XECXVTx-1224-x	11'-11"	24'-1/2"	11'-10 13/16"	11'-8 1/8"
CXVT-x-1426-x and XECXVTx-1426-x	13'-11 1/8"	26'-3 1/2"	13'-5/16"	13'-8 1/4"

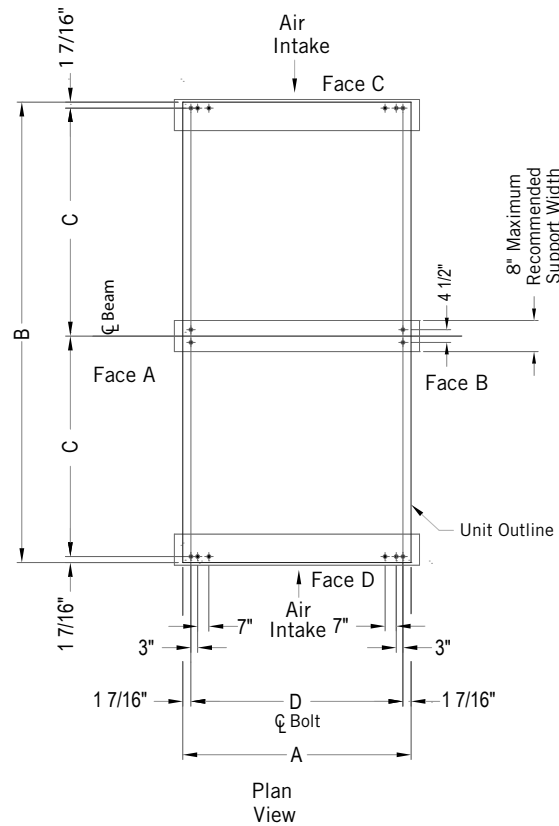

CXVT

## CXVB

Model Number	D
CXVB-x-0806	8'-3 1/2"
CXVB-x-0809	8'-3 1/2"
CXVB-x-0812	8'-3 1/2"
CXVB-x-0818	8'-3 1/2"
CXVB-x-1212	11'-7 3/4"
CXVB-x-1218	11'-7 3/4"
CXVB-x-1224	11'-7 3/4"
CXVB-x-1236	11'-7 3/4"

