



**BALTIMORE
AIRCOIL AUSTRALIA**



PCT

PCT Cooling Tower

RIGGING & ASSEMBLY INSTRUCTIONS

PCT Cooling Towers should be rigged and assembled as outlined in this manual.

These procedures should be thoroughly reviewed prior to the actual rigging and assembly of the equipment to acquaint all personnel with procedures to be followed and to ensure that all necessary equipment will be available beforehand.

If outstanding circumstances require a departure from the procedures outlined in this manual, contact your local BAC Representative for guidance.



Be sure to have a copy of the submittal drawings available for reference. If you do not have a copy of these drawings, or if you need additional information about this unit, contact your local BAC Representative whose name and telephone number are on the outside of the cold water basin. The model number and serial number of the unit are also located in this area.



Table of Contents

RIGGING & ASSEMBLY INSTRUCTIONS » PCT COOLING TOWER

1 Introduction

- 2 Safety
- 2 Shipping
- 2 Pre-Rigging Checks
- 3 Cold Weather Operation
- 3 Location
- 3 Warranties
- 3 Unit Operation

2 Unit Rigging & Assembly

- 4 Rigging
- 5 Section Assembly
- 6 Field Sealing of Basin to Casing Post Joint
- 7 Multi-Cell Unit Installation
- 9 Roof Deck Section Lifting

3 Optional Accessory & Loose Item Installation

- 10 Air Inlet Louvres
- 10 Float Valve
- 11 Fitting Tie Braces
- 12 Fitting of Wind Walls
- 13 Piping
- 13 Fan Speed
- 13 Bleed Line Installation
- 14 Basinless Unit Installation
- 15 Platform Installation

1 Introduction

WARNING: Failure to use designated lifting points can result in a dropped load causing severe injury, death, and/or property damage. Lifts must be performed by qualified riggers following BAC published Rigging Instructions and generally accepted lifting practices. The use of supplemental safety slings may also be required if the lift circumstances warrant its use, as determined by the rigging contractor.



WARNING: Only personnel qualified to do so should undertake the installation, operation, maintenance, and repair of this equipment. Proper care, procedures, and tools must be used in handling, lifting, installing, operating, maintaining, and repairing this equipment to prevent personal injury and/or property damage.



Safety

Adequate precautions appropriate for the installation and location of these products should be taken to safeguard the equipment and the premises from damage and the public from possible injury. **The procedures listed in this manual must be thoroughly reviewed prior to rigging and assembly. Read all warnings, cautions, and notes detailed in the margins.**

When the fan speed of the unit is to be changed from the factory set speed, including the use of a variable speed device, steps must be taken to avoid operating at or near the fan's "critical speed" which could result in fan failure and possible injury or damage. Consult with your local BAC Representative on any such applications.

Shipping

BAC PCT Cooling Towers are factory assembled to ensure uniform quality with minimum field assembly. As standard, models ship in two sections per cell (lower and upper). Optional shipment of three sections per cell and optional containerized shipments are available. Contact your local BAC Representative for more information. For the dimensions and weights of a specific unit or section, refer to the submittal drawings.

Pre-Rigging Checks

When the unit is delivered to the jobsite, it should be checked thoroughly to ensure all required items have been received and are free of any shipping damage prior to signing the bill of lading.

The following parts should be inspected:

- Sheaves and Belts
- Bearings
- Bearing Supports
- Fan Motor(s)
- Fan Guard(s)
- Fan(s) and Fan Shaft(s)
- Float Valve Assembly(s)
- Fill
- Water Distribution System
- Cold Water Basin Accessories
- Interior Surfaces
- Exterior Surfaces
- Louvres
- Mating Surfaces Between Sections/Modules
- Miscellaneous Items: All bolts, nuts, washers, and sealer tape required to assemble sections or component parts are furnished by BAC and shipped with the unit. A checklist inside the envelope marked "Customer Information Packet" indicates what miscellaneous parts are included with the shipment and where they are packed. This envelope will be attached to the side of the unit or located in a box inside the unit.



Safety

Shipping

Pre-Rigging Checks

Unit Weights

Anchoring

Cold Weather Operation

Location

Warranties

Unit Operation



ATTENTION: Before an actual lift is undertaken, ensure no water, snow, ice, or debris has collected in the basin or elsewhere in the unit. Such accumulations will add substantially to the equipment's lifting weight.

Unit Weights

Before rigging any unit, the weight of each section should be verified from the unit submittal drawing. Unit print weights include the final assembled tower with all accessories.

Anchoring

Holes suited for M16 bolts are provided for bolting the unit to the support beams. Refer to the suggested support drawing included in the submittal for location and quantity of the mounting holes. **The unit must be level for proper operation.** Anchor bolts must be provided by others.

Support beams must also be level. Each footing should be shimmed with a firm material to ensure the weight of the tower is carried at all points and that the basin ledges are level at all places. Shims may be required either side of a joint. This is to be done before the basin is filled with water. If vibration isolators are used, a supporting framework must be provided between the unit and the vibration isolators to provide continuous and rigid support. Anchor bolts, footings and beams to be supplied by others.

Cold Weather Operation

These products must be protected by mechanical and operational methods against damage and/or reduced effectiveness during sub-freezing temperatures. Please contact your local BAC Representative for recommended cold weather operation strategies.

Location

All evaporative cooling equipment must be located to ensure an adequate supply of fresh air to the fans. When units are located adjacent to walls or in enclosures, care must be taken to ensure the warm, saturated, discharge air is not deflected and recirculated back to the air intakes.

Each unit must be located and positioned to prevent the introduction of discharge air into the ventilation systems of the building on which the unit is located and of adjacent buildings. For detailed recommendation on BAC equipment layout, please contact your local BAC Representative.

Warranties

Please refer to the Limitation of Warranties (located in the submittal package) applicable to and in effect at the time of the sale/purchase of these products.

Unit Operation

Prior to start-up and unit operation, refer to the PCT Operation & Maintenance Manual shipped with the unit.

Unit Rigging & Assembly

NOTE: For weight information, refer to the submittal drawing package.



Rigging

To simplify shipping, rigging and installation all PCT Cooling Towers are shipped in major sections consisting of a basin assembly(s) and one or more casing/roof deck sections (see **Table 1**).

| NOMINAL BOX SIZES | No. of | | NOMINAL BOX SIZES | No. of | | NOMINAL BOX SIZES | No. of | | H1 | H2 | L |
|-------------------|----------|--------|-------------------|----------|--------|-------------------|----------|--------|----------|---------|---------|
| | Basin | Casing | | Basin | Casing | | Basin | Casing | (fig 2a) | (fig 3) | (fig 3) |
| | Sections | | | Sections | | | Sections | | (mm) | (mm) | (mm) |
| 5' x 5' | 1 | each | - | 2 | each | - | 3 | each | 1200 | 1700 | 1500 |
| 6' x 6' | | | - | | | - | | | 1600 | 1900 | 1800 |
| 7' x 7' | | | - | | | - | | | 1900 | 2200 | 2100 |
| 8' x 8' | | | 8' x 16' | | | 8' x 24' | | | 2200 | 2500 | 2400 |
| 7' x 10.5' | | | - | | | - | | | 2900 | 2200 | 3300 |
| 9' x 9' | | | 9' x 18' | | | 9' x 27' | | | 2400 | 2700 | 2800 |
| 8' x 12' | | | - | | | - | | | 3500 | 2500 | 3700 |
| 10' x 10' | | | 10' x 20' | | | 10' x 30' | | | 2700 | 3000 | 3000 |
| 11' x 11' | | | 11' x 22' | | | 11' x 33' | | | 2900 | 3300 | 3400 |
| 9' x 13.5' | | | - | | | - | | | 4000 | 2700 | 4200 |
| 10' x 15' | | | - | | | - | | | 4500 | 3000 | 4700 |
| 11' x 16.5' | | | - | | | - | | | 5000 | 3300 | 5100 |

*** Casing Section Includes Roof Deck (Fan Assembly) ***

Table 1. Recommended Dimensions for Rigging

NOTE: Any motors or accessories shipped in the cold water basin must be removed prior to installation.



WARNING: Unless units ship fully assembled, basin & casing/roof deck sections must be rigged separately. Never assemble the unit before lifting as the lifting devices provided on the unit are not designed to support the weight of the entire assembled unit. THE USE OF SAFETY SLINGS IS RECOMMENDED FOR EXTENDED LIFTS OR WHENEVER HAZARDS EXIST.



The proper rigging sequence for the PCT series is to lift the basin section(s) into place first. On multi-section basins lift each section into place separately and then bolt sections together. Next, lift each casing section into place and secure to the basin section. If motor(s) are supplied loose fit the motors. **At the completion of this stage a crane is no longer required.**

Finally securely bolt the unit to supporting steel and on multi-section basins seal the joint between sections.

Table 1 gives the recommended dimensions for rigging each section of any PCT unit. With the information from the table and the additional instructions on the following pages the rigging of a PCT Cooling Tower can be quickly accomplished.

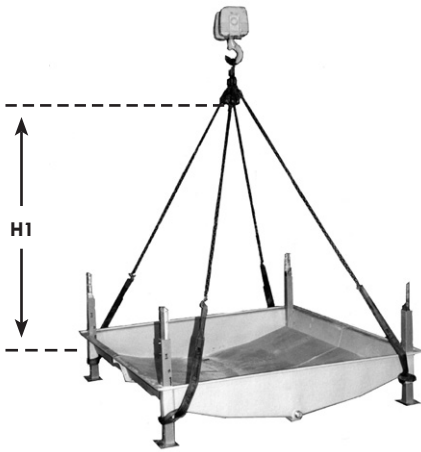

Figure 1. Lifting basin section

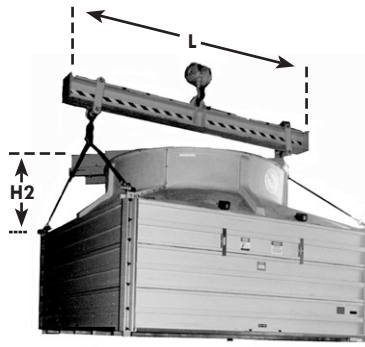

Figure 2. Lifting casing/roofdeck section

Section Assembly

1. Remove any motors or accessories shipped in the cold water basin.
2. **Figures 1** and **2** show the proper rigging of the sections for units that ship in two sections. Position the lower section on the steel support and bolt in place.
3. Using basin to casing joining brackets, guide the upper section onto the lower section. Match marks must line up.
4. Fasten the hardware between the upper casing and lower section per **Figure 3a** and **3b**.
5. Seal the joint between the upper section and lower section as described on page 6.

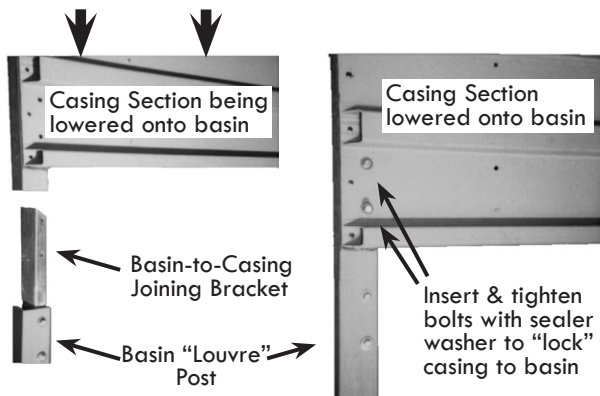

Figure 3a. Joining Casing to Basin section



Figure 3b. Joining Casing to Basin section

Field Sealing of Basin to Casing Post Joint

Procedure:

1. Clean area for 30mm either side of the joint. Total width 60mm. Use emery paper to rough up surface and remove sheen. Wipe with acetone and allow to dry.
2. Wrap a layer of masking tape around post 30mm below joint and a layer 30mm above the joint. This will assist in limiting spread of excess sealer beyond sealing area.
3. Apply enough sealer on all faces of the square posts to give 2mm thick coverage 30mm either side of the joint. Use a scraper to spread this evenly over the surface. The sealer has a working time of 30 minutes before skinning over.
4. Wrap fiberglass cloth over the joint and press into the sealer. Cloth provided should wrap around the post approximately three times.
5. Apply and spread extra sealer if required to ensure fiberglass cloth is coated with sealer.
6. Remove masking tape applied at step (2) and tidy up edges with a scraper.

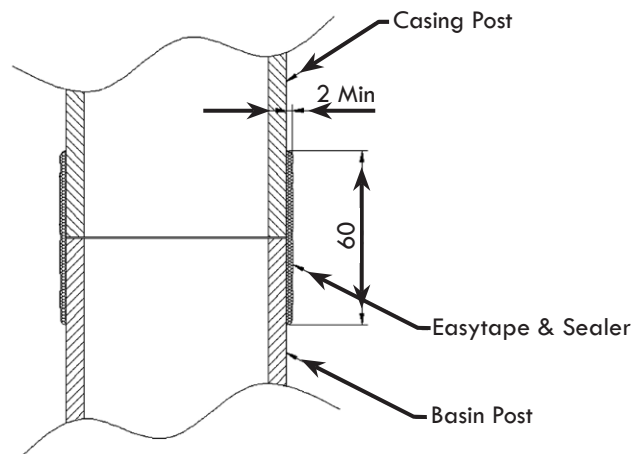

Figure 4. Sealing of Basin to Casing Post Joint

Multi-Cell Unit Installation

Refer to the submittal drawing unit print for the proper orientation of each cell. Multi-cell unit installations require field sealing of the basin where the two cells are joined. The following procedure should be followed to join basin sections.

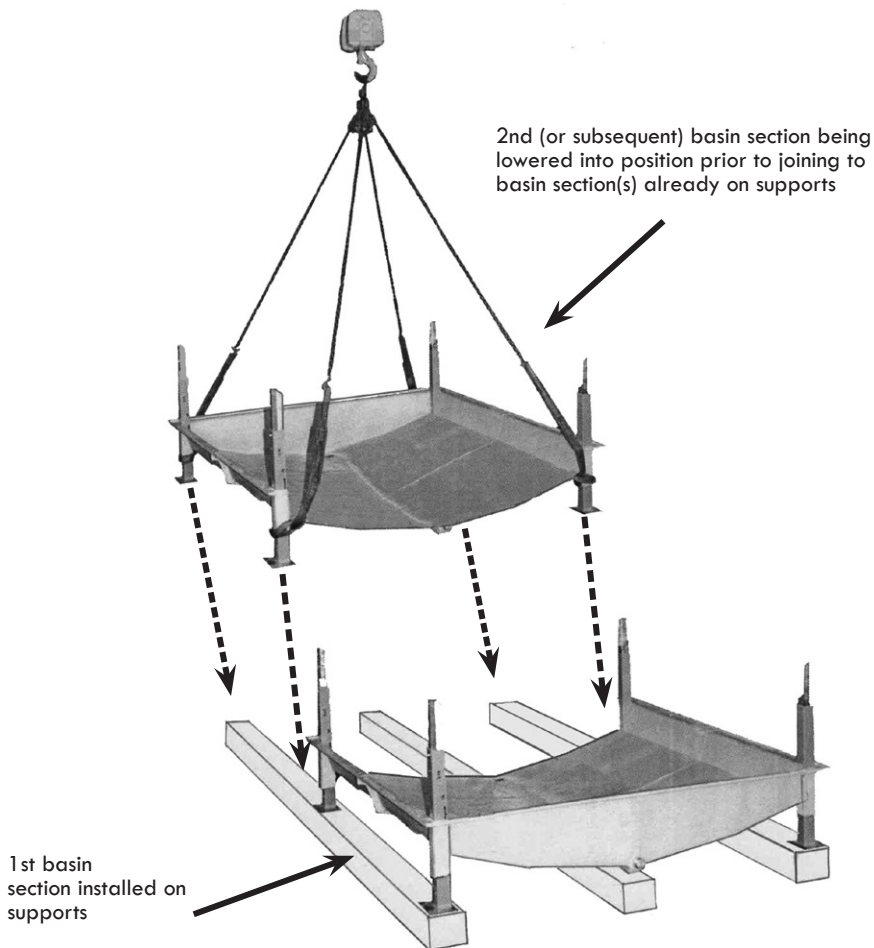

Figure 5. Installing Multi-section basin

Procedure:

1. Use jigs or clamps to hold basin sections together temporarily. When aligned, re-drill any holes that do not align properly.
2. Prepare the joint. Use Acetone and a scraper to clean the faces of the joint to remove smears or deposits of fiberglass release agent, loose paints or filler materials such as Plasticine. Abrade the mating faces of the basin to at least 50mm from the corner. Clean and abrade the corners. Clean and abrade 12mm of the exposed edges of the basin adjacent to the joint (see **Fig 6**). Note that the key area for sealing and gluing is regarded as the 50mm part of the joint closest to the water.
3. Wipe with acetone to remove dust.
4. Apply 5mm diameter beads of sealant around the perimeter of the abraded prepared areas. Fill in the area with a 5mm bead in striped or a serpentine pattern. Sealer is to be applied to both faces in this manner.
5. Pull the basin sections close together so that beads of sealant touch. Fit a bolt in each hole, with a nut & 2 washers, and do up finger tight.
6. Smooth over the joint with spatula, removing excess sealant or adding extra to fill hollows.
7. Do not disturb for 2 hours.
8. After 2 hours, bolts can be tightened further to put pressure on joint.

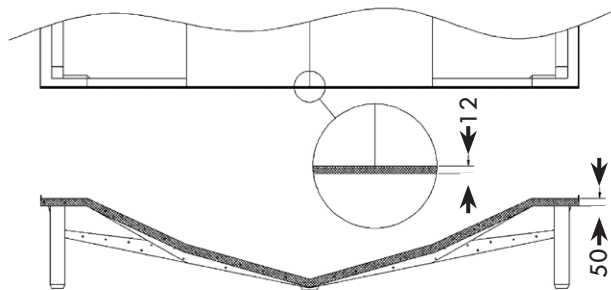

Figure 6. Abrading of basin halves

Roof Deck Section Lifting

In certain situations it may be required that the roof deck section be shipped separate to the casing. In this situation lifting of the roof deck section will be required on site to position it back on the casing. Where units are shipped in this orientation, extra lifting ears are added to the roof deck.

The sketch below shows the orientation of each lifting ear as it bolts to the joining flange between segments. For direct drives one lifting ear per roof deck flange joint will be fitted. In the field, for belt drives the lifting will take place with one sling around the motor and three slings to the lifting ears. For this reason, the lifting ears are only fitted to the three flanges not covered by the motor and mechanical equipment support. **These lifting ears are for use when lifting the roof deck section only. They should not be used for lifting the entire casing section.**

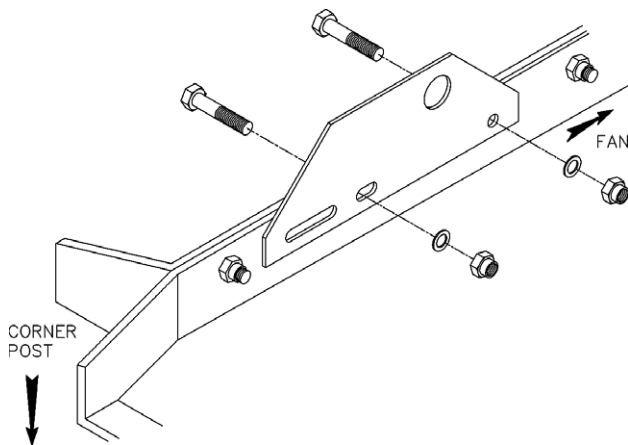

Figure 7a. Lifting Lugs for Roof Decks

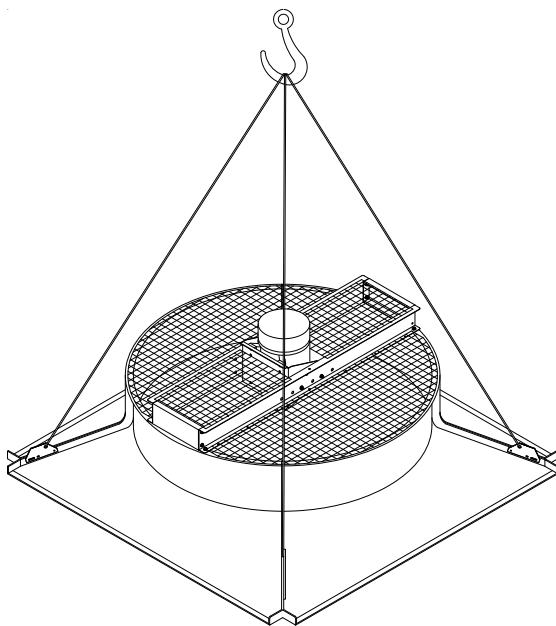

Figure 7b. Lifting Roof Decks



WARNING: UNDER NO CIRCUMSTANCES SHOULD THE ROOF DECK LIFTING EARS BE USED FOR LIFTING THE CASING SECTION. THEY ARE ONLY DESIGNED FOR LIFTING THE ROOF DECK.

3 Optional Accessory & Loose Item Installation

AIR INLET LOUVRES

Air inlet louvres are a lift and drop in design. They are to be installed with flutes facing downwards into basin. A shorter louvre is provided to fit over the quick fill/makeup.

FLOAT VALVE

If the unit has shipped without the float arm/ball assembly attached this should be installed as per **Figure 8**, before louvres are installed.



Figure 8. Attaching float arm

FITTING TIE BRACES

Some PCT units are fitted with tie braces on the basin legs to provide structural stiffness to the unit. Where possible these are factory fitted although if they are shipped loose they will need to be fitted in the field. The following procedure should be followed to fit the tie braces:

1. Once the basin has been levelled out and shimmed, and prior to the casing being fitted, an inspection should be made to ensure that all posts are reasonably vertical and that the basin is supported in all nine places [or twelve places for rectangular units].
2. Fit the diagonal tie braces at their top end only picking up pre-drilled holes in the post. Do not drill the bottom tie brace holes in the posts yet. The tie braces have a bend to give stiffness. The bent edges should be oriented so that they will deflect water into the basin.
3. Place the casing on top of the basin legs with the majority of the weight being carried by the crane. **DO NOT REMOVE THE CRANE UNTIL ALL TIE BRACES ARE TIGHTENED.**
4. Check that posts are vertical and aligned correctly. The weight of the casing and the position of the crane can skew the posts sideways and may need adjustment. Swing the tie braces so that the lower hole is centred in the basin post. If the posts are parallel and square, the holes should be an equal distance up from basin ledge. Once the posts are square, tie braces should be pulled tight and clamped. The bolt holes may now be drilled and bolts fitted. Now tighten all tie brace bolts. The crane can now be released.

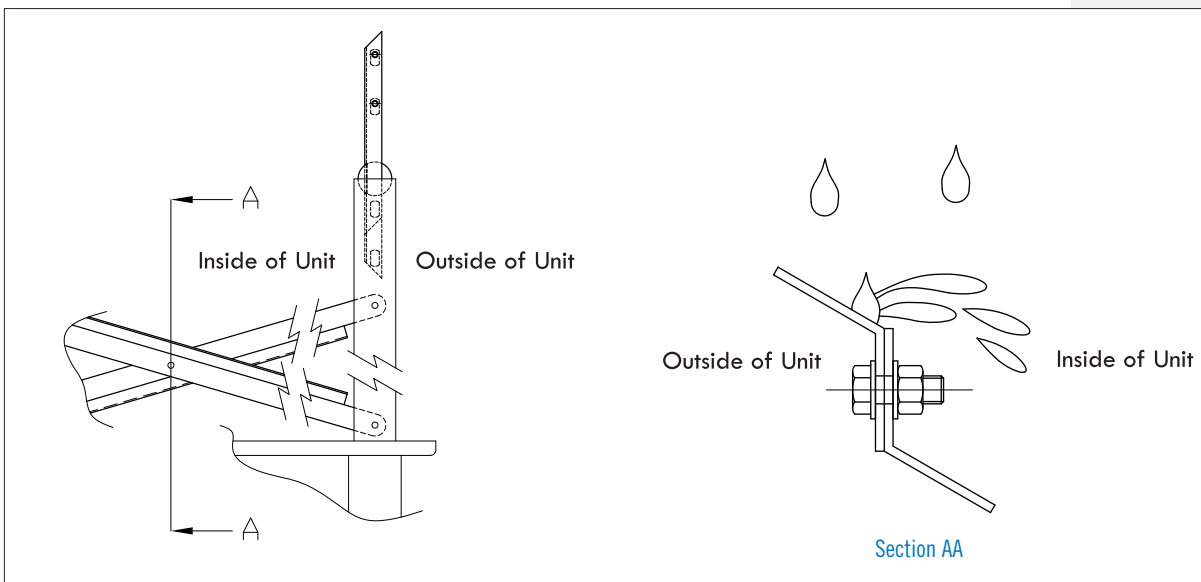

Figure 9. Fitting Tie Braces

FITTING OF WIND WALLS

1. Prior to fitting flashing, the following steps in installation should have taken place: (a) Basin(s) placed in position and shimmed to make level and carry weight evenly. (b) Casing lowered onto basin legs and the leg joiners bolted together.
2. With the casing bolted to the basin, seal the joints between the posts.
3. There are two flashing pieces provided for each side of the unit. Each flashing piece rests on the fiberglass ledge of the basin wind wall. The wind wall is not fully glued to the post and can be temporarily pulled away from the post to slide the flashing in. Each flashing piece has a folded end to prevent water falling out. When the flashing is in the correct place, this folded end is sealing against the outside face of the corner post. The flashing pieces overlap by approximately 30mm. They are not designed to be bolted together.
4. To fix the flashing in position, screw the Z-section brackets to the flashing pieces so as to pull the flashing against the upper fiberglass panel. Sealer is applied to the fastener as it is fitted to prevent water migration through the fastening points.
5. When the flashing is in place, there is a cavity created behind the corner posts and sealing is required within this area. (a) Use the sealer provided to seal the bottom horizontal corners behind the post. (b) Seal the vertical joint between the post and flashing ends.
6. Seal the vertical joint where flashing pieces overlap each other.
7. It is not envisaged that sealing is needed on any of the other horizontal joints such as where flashing overlaps fiberglass panels.

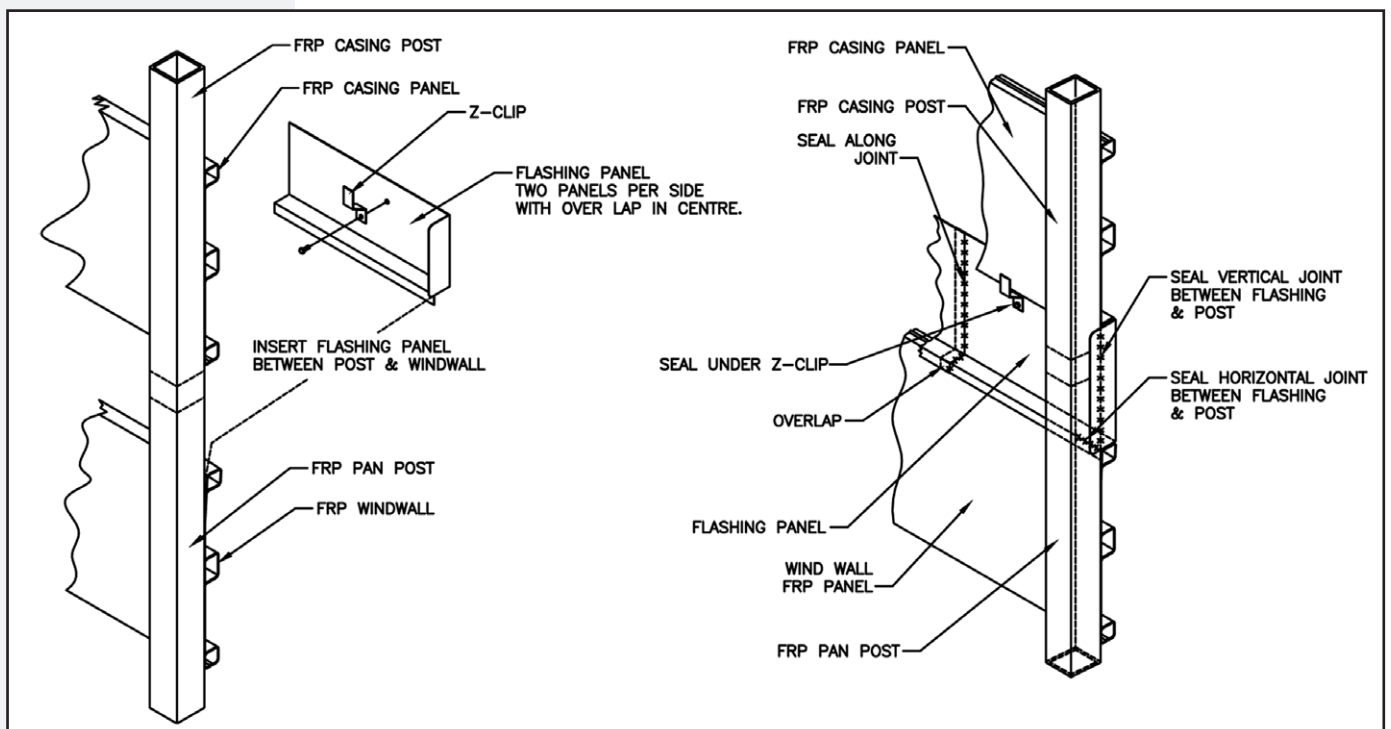

Figure 10. Fitting of Wind Walls

PIPING

All piping must be supported external to the tower and restraint provided to ensure no vertical or horizontal movement of the piping. All piping and supports are to be furnished by others.

FAN SPEED

When the fan speed of this product is to be changed from the factory set speed, including the use of a variable fan speed control device, steps must be taken to avoid operating at or near the fan's "critical speed" which could result in fan failure and possible injury or damage.

BLEED LINE INSTALLATION

On all PCT units install a bleed line with valve between the system circulating pump discharge riser and a convenient drain. Locate the bleed line in a portion of the riser piping that drains when the pump is off.



Optional Accessory & Loose Item Installation

Fitting of Wind Walls

Piping

Fan Speed

Bleed Line Installation



WARNING: The bleed valve should always be open when the unit is in operation, unless the bleed rate is automatically controlled by a water treatment system.

Recommended bleed rates may be found in the Operating and Maintenance Manual or by consulting a competent water treatment specialist.

BASINLESS UNIT INSTALLATION

Units supplied without a basin come in one of two arrangements, “A” or “B”.

Arrangement “A” - This is where the unit is supplied with the casing, roof deck and mechanical equipment only. This arrangement does not include any louvres, legs, strainer, suction, drain, quick-fill or make-up. The casing section sits directly onto supporting piers or beams supplied by others. Since the unit is essentially now only a casing/roof deck section, the unit is rigged as per **Figure 2**.

Arrangement “B” -With this arrangement the unit is supplied the same as above but also includes louvres and a louvre support frame consisting of legs channels and tie braces. This support frame is shipped unassembled to minimise transport costs and must first be assembled in place.

See **Figure 11** below demonstrating this assembly. See also “FITTING TIE BRACES” on page 11 for correct installation of the tie braces. Once the frame is assembled the casing section can then be lifted on and fastened using the basin to casing joining bracket shown in **Figure 3b**.

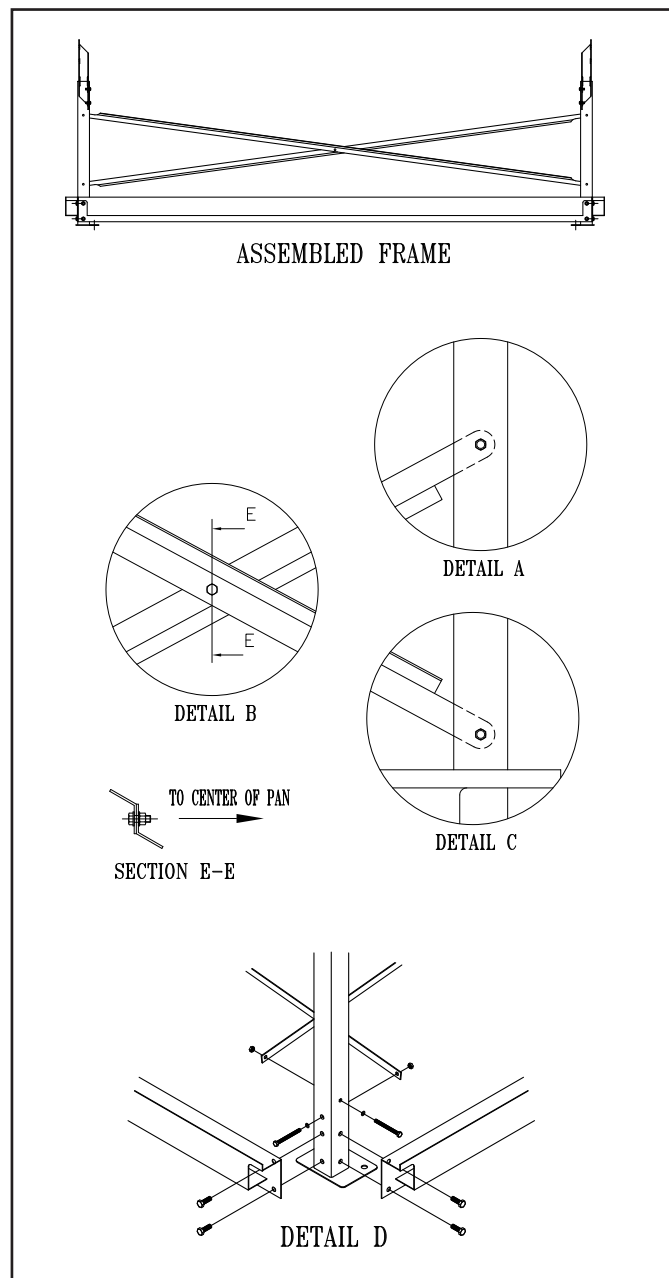

Figure 11

PLATFORM INSTALLATION

Factory Fitted Platforms

Where a platform is supplied with the unit it is normally fitted to the casing section at the factory. In this case only the ladder, stiles and landing need to be fitted on site. See figure 12a below demonstrating this.

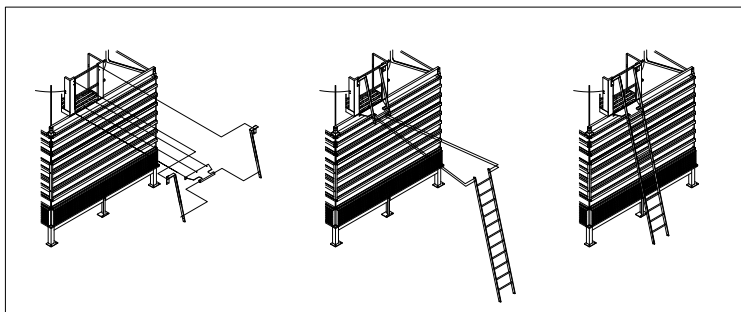

Figure 12a.

Pre-Assembled Platforms Shipped Loose

In some instances due to transport limitations it is necessary to ship the platform separate from the unit. In this case the platform must first be lifted up and fixed to the platform support beam. See figure 12b below demonstrating this. Once the platform is fitted to the support beam the ladder, stiles and landing can be fitted as above.

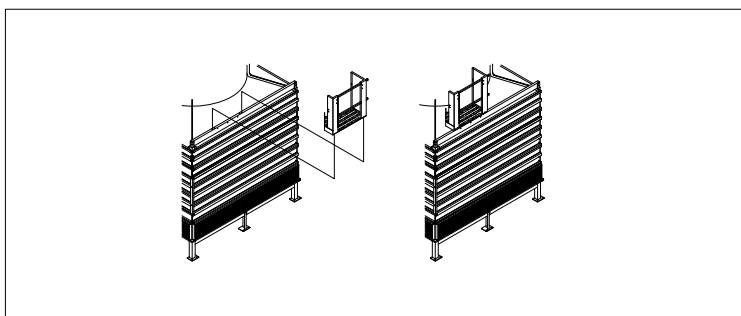

Figure 12b.

Knock Down Platforms

Platforms may be shipped as a knock down kit for assembly on site if required. If this is the case the platform must first be assembled on the floor before being lifted into place. Figure 12c below shows an exploded view of a typical platform.

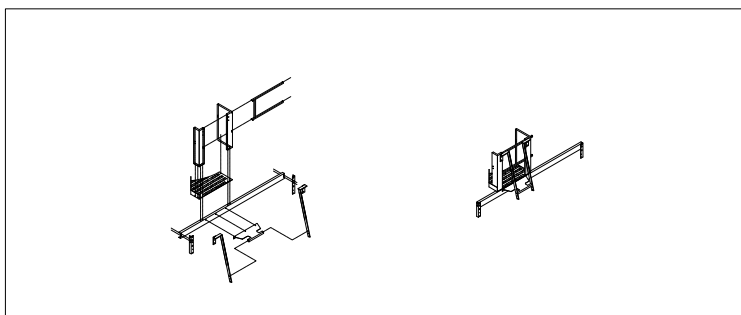

Figure 12c.

COOLING TOWERS

CLOSED CIRCUIT COOLING TOWERS

ICE THERMAL STORAGE

EVAPORATIVE CONDENSERS

HYBRID PRODUCTS

PARTS & SERVICES



www.BaltimoreAircoil.com.au

120 Wisemans Ferry Road, Somersby NSW 2250 > Telephone (Australia): 1300.134.622 > Telephone (New Zealand): 0800.225.842